

# Design and Development of Microcontroller Based Quasi Square Wave Inverter (QSI) for Elevator Illumination application

**Sharanbasav Marihal1**

*1Assistant professor, Department of Electrical & Electronics Engineering, SGBIT, Belagavi, affiliated to VTU Belagavi, Karnataka, India*

*Dr. B. V. Madiggond<sup>2</sup>*

*<sup>2</sup>Professor & Head Department of Electrical & Electronics Engineering HIT, Nidasoshi, affiliated to VTU Belagavi, Karnataka, India*

## Abstract

The paper aims at designing Quasi Square wave Inverter (QSI), which is MOSFET based PWM (Pulse Width Modulation), to illuminate the elevator cab. Switching techniques are used rather than linear circuits in power stage, because switching techniques are more efficient and thus less expensive. These inverters require no high frequency switching as the switching takes place at line frequency. The regulation is achieved by varying width of the rectangular pulses, to control the 'Form Factor' and hence the RMS value of the output voltage. This is called PWM and is done by having a feedback system which senses the inverter's output voltage. Atmel ATmega88 is a low-power CMOS 8-bit microcontroller based on the AVR Enhanced RISC architecture. By executing powerful instructions in a single clock cycle, the ATmega88 achieves throughput's approaching 1 MIPS per MHz allowing the system designed to optimize power consumption versus processing speed.

**Keywords** — *AC-DC converter, Atmega88 microcontroller, DC-AC converter, Power transformer, Switching pulse generation, PWM.*

## I. INTRODUCTION

AN inverter is a circuit that converts battery power (DC) into an alternating current (AC). This means that most inverters are installed and used in conjunction with a battery bank. The proposed design is probably the most popular and economical type of power inverter. It produces an AC waveform somewhere between a square wave and a pure sine wave. Quasi Square Wave Inverters, sometimes called Modified-Square Wave inverters, are not real expensive and work well in all but the most demanding applications and even most computers work well with a Modified Sine Wave inverter [1]. However, there are exceptions. Some appliances that use motor speed controls or that use timers may not work quite right with a Quasi Square Wave inverter.

The objective of the paper is to design and implement a low cost 60w quasi square wave inverter for elevator illumination application, using switched mode converters and atmega88 microcontroller, and to provide power

for telephone and alarms when power goes off. The emergency light and alarm system will give entrapped passengers a sense of security.

Two power converter topologies are used to achieve the desired objective. i) The AC to DC diode bridge rectifier to charge the battery when mains power is available. ii) The push-pull converter to convert battery DC power to AC power when mains power is cut off.

The battery voltage which varies from 10.5V to 14.4V is converted to AC voltage at line frequency by means of MOSFET push-pull inverter which is switched by MOSFET driver circuit. The inverter output is transformer coupled for electrical isolation and step up the AC voltage.

Atmega88 will process the various analog and digital signals [5]. The gate pulse generation, voltage and current sensing, protective operation, LED indication are controlled by a single microcontroller which makes the design very compact.

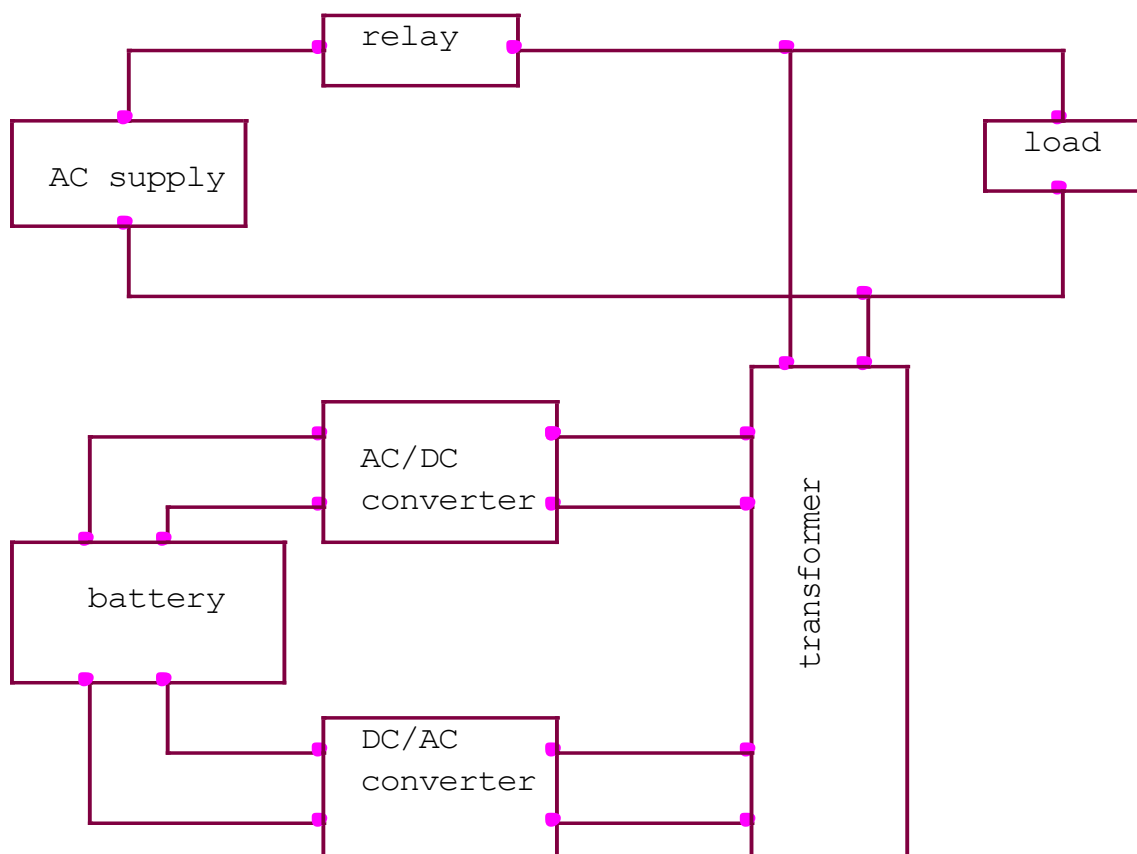

**Figure 1.** Block diagram of QSI

The AC Mains input will be a 230V 50Hz voltage. This will power up the load and charge the battery while it has power. The relay will take the information from the microcontroller and determine when it is possible to switch between the ac line and the inverter system. The AC/DC converter will provide the regulated DC power to charge the battery which is a 12V, 7Ah sealed lead-acid battery. The battery will supply power to the load

when the ac line loses power. The inverter will change the DC power from the battery to AC power for the load. It will convert the dc voltage to an approximate 230V 50Hz modified square signal.

TABLE I  
DESIGN SPECIFICATIONS

Sl.No	Specification	Range
1	Nominal output power	40Watts
2	Input voltage	190Vac-270Vac
3	Output voltage	230V±15Vac
4	Battery output frequency	50Hz±1%
5	Output waveform in mains mode	Normal sine wave
6	Output waveform in battery mode	Quasi square wave
7	Back up time	55min for 40W
8	Battery capacity	12V,7Ah

## II. DESIGN OF MODIFIED SQUARE WAVE INVERTER

### A. Power transformer design

The power transformer consists of single primary winding (PRI) and two secondary windings (SEC1 & SEC2).

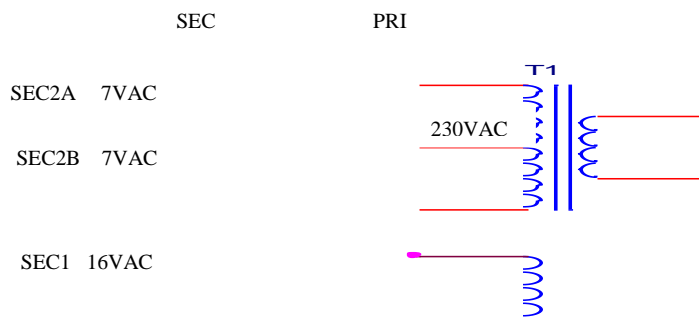

Figure 2. Power transformer

Equation for voltage induced in transformer winding

$$V = 4FfaNB \times 10^{-8} \quad (1)$$

The above equation can be simplified and written as

$$\frac{N}{V} = \frac{39}{8.142} = 4.79 \quad (2)$$

Number of turns in primary =  $4.79 \times 230 = 1102$

Number of turns in sec1 =  $4.79 \times 16 + 10\%$   
 $= 80.472 + 8.047 = 85$

$$\begin{aligned} \text{Number of turns in sec2A} &= 4.79 \times 7 + 10\% \\ &= 33.53 + 3.353 = 37 \end{aligned}$$

$$\begin{aligned} \text{Number of turns in sec2B} &= 4.79 \times 7 + 10\% \\ &= 33.53 + 3.353 = 37 \end{aligned}$$

Current density is,

$$J = \frac{P_t \times 10^4}{K_f \times K_u \times f \times B_m \times A_p} \quad (3)$$

Where,

P<sub>t</sub> – apparent power in volt-ampere, K<sub>f</sub>=4.44; K<sub>u</sub>=0.4; f=50Hz, A<sub>p</sub> = area product=9.04sq.cm

$$J = \frac{46.04 \times 10^4}{4.44 \times 0.4 \times 50 \times 1.3 \times 9.04} = 443.13 \text{amps/cm}^2$$

Wire size for primary:

Considering worst case tolerance is given for input current

$$A_w = \frac{I_p}{J} = \frac{1.2}{443.13} = 2.7 \times 10^{-3} \text{cm}^2 \quad (4)$$

The wire size corresponding to above value

AWG#22 with  $3.2430 \times 10^{-3} \text{cm}^2$

Wire size for secondary1:

Taking twice the rated current

I<sub>sec1</sub>=2A, from (4)

$$A_w = \frac{2}{443.13} = 4.514 \times 10^{-3} \text{cm}^2$$

This corresponds to AWG#20 with  $5.1880 \times 10^{-3}$

Wire size for secondary1:

I<sub>sec2A</sub> = I<sub>sec2B</sub> = 5A, from (4)

$$A_w = \frac{5}{443.13} = 11.28 \times 10^{-3} \text{cm}^2$$

This corresponds to AWG#16 with  $13.07 \times 10^{-3}$

## B. Battery charger

Battery charger is essentially a regulated DC power supply which can operate in constant current and constant voltage modes as desired. A simple charging profile which gives good results features a current limit, then a voltage limit.

The charging circuit shown in figure 3 is designed for 13.8V, 0.8A dc supply. The stepped down AC voltage from the secondary of transformer is rectified to DC by the full bridge diode rectifier, and filtered output is given to LM317T a three pin adjustable regulator. The output of LM317T regulates the charging voltage to a constant value for any change in line or load voltages.

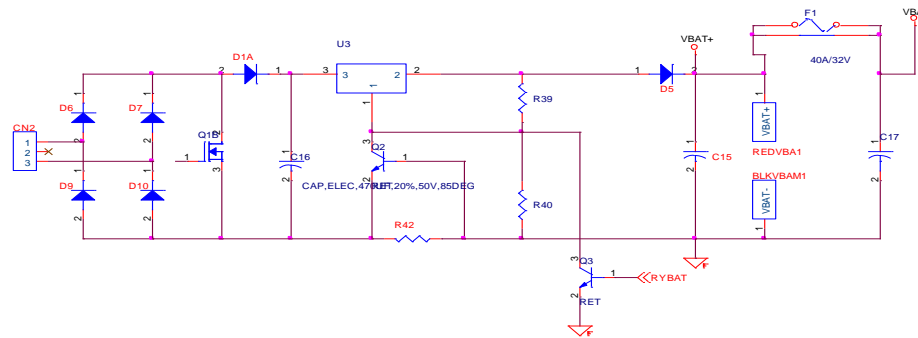

Figure 3. Battery charger circuit

Full Bridge Diode Rectifier Design

$$V_{ACSEC} = 16.8V; \quad I_{ACSEC} = 1.4A$$

For full bridge rectifier, rectified dc output is

$$V_{dcpeak} = 1.41 \times V_{ACSEC}$$

$$= 1.41 \times 16.8 = 23.688V$$

$$V_{dcavg} = 0.90 \times V_{ACSEC}$$

$$= 0.90 \times 16.8 = 15.12V$$

$$I_{dc} = 0.62 \times I_{ACSEC}$$

$$= 0.62 \times 1.4 = 0.868A$$

Selected diode: S3B, 100V, 3A, SMC

**Push – Pull converter**

DC voltage from the battery is converted into AC by using a pair of power MOSFETs as shown in figure 4. The positive 12V DC from the battery is connected to the centre tap of the transformer primary. When Q1 (top MOSFET), is turned ON, the battery current flow through the upper half of the primary transformer and to ground via Q1. By switching on Q2 (bottom MOSFET) instead, the current will flow in the opposite direction. Therefore by switching ON the two MOSFETs alternatively, an alternating magnetic flux is produced in the transformer’s core. As a result, according to the principles of transformer we have on the secondary winding a rectangular wave AC voltage of around 650V peak to peak [3].

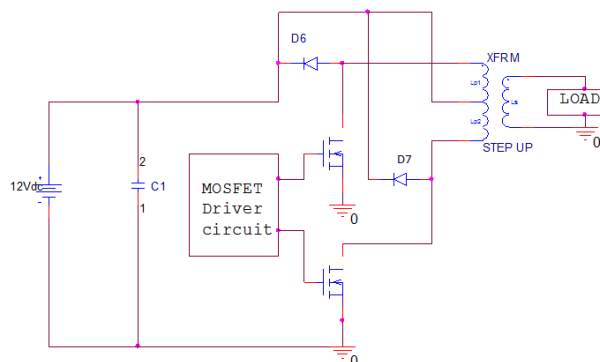

Figure 4. Push – Pull inverter circuit diagram

The output voltage regulation is achieved by varying the width of the driving pulses of MOSFETs, and hence the RMS value of the output voltage. It is usually done by having a feedback system which senses the inverters output voltage. When this feedback senses that the output voltage began to decreased, the MOSFET driving circuit inverters acts to increase the width of the pulses which turn ON the MOSFETs. The MOSFETs turn ON for longer time at each half-cycle, automatically correcting the RMS value of the output voltage in order to compensate any drop in peak-to-peak output voltage.

**C. Atmega88 Microcontroller**

Atmel ATmega88 is a low-power CMOS 8-bit microcontroller based on the AVR Enhanced RISC architecture. By executing powerful instructions in a single clock cycle, the ATmega88 achieves throughputs approaching 1 MIPS per MHz allowing the system designed to optimize power consumption versus processing speed. The ATmega88 features a 10-bit successive approximation ADC. The ADC is connected to an 8-channel analog Multiplexer which allows eight single-ended voltage inputs.

The ATmega88 AVR is supported with a full suite of program and system development tools including: C Compilers, Macro Assemblers, and Program Debugger/Simulators, In-Circuit Emulators, and Evaluation kits.

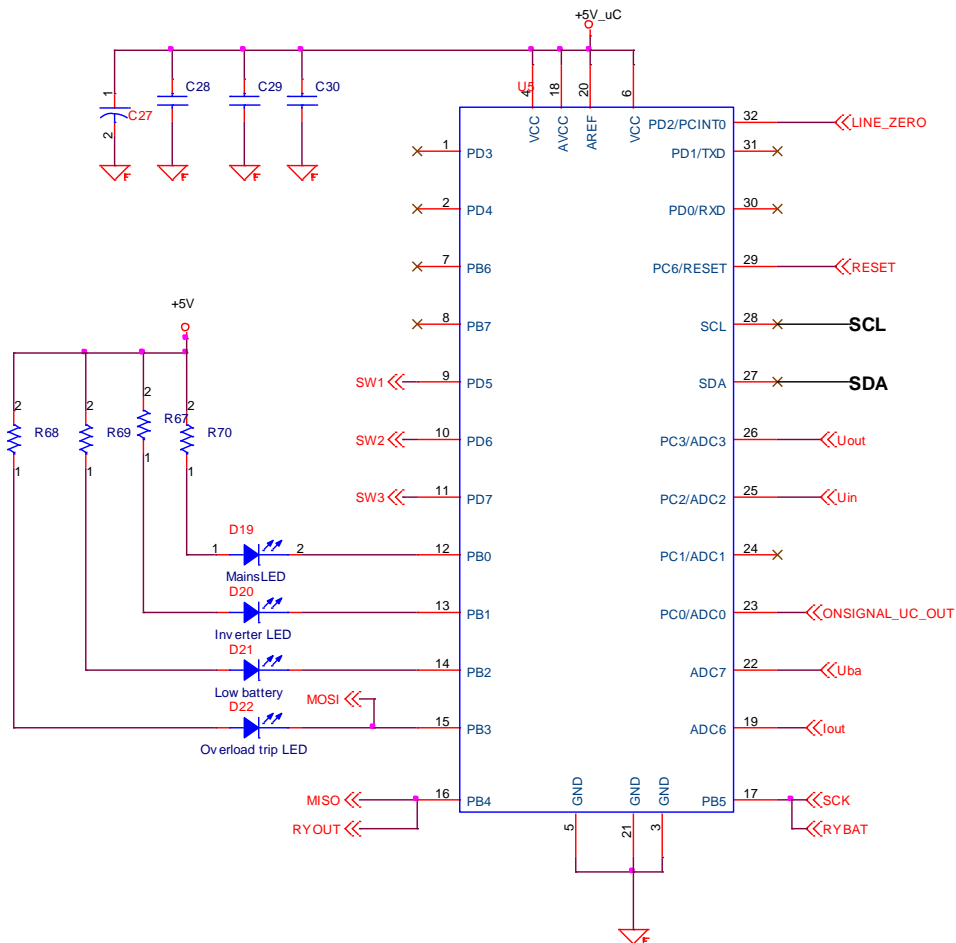
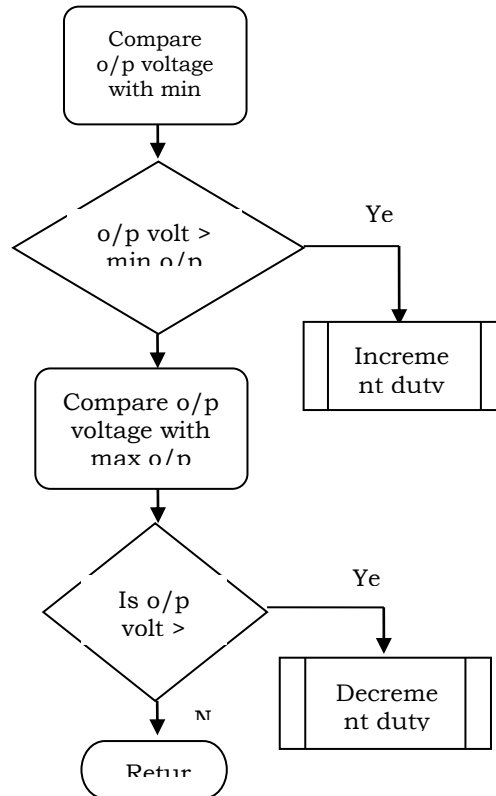

Figure 5. Pin out of atmega88 microcontroller

Program Flow for Gate Pulse Width Variation



III. EXPERIMENTAL RESULTS

The MOSFETs gate pulses are shown in figure 6 and figure 7 for different load conditions. It can be seen that the width of gate pulses will increase from no- load to full load, to regulate the output voltage.

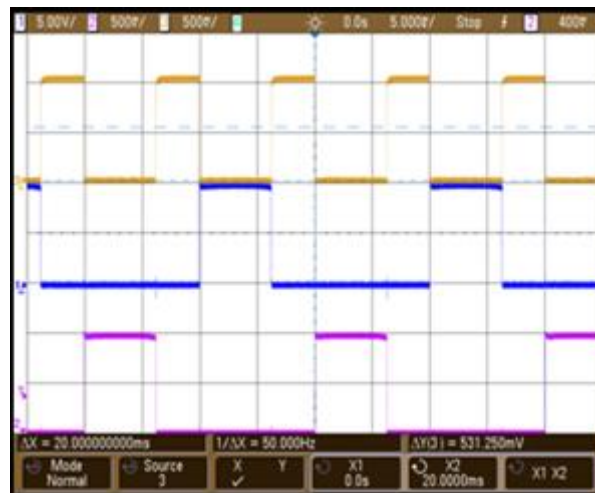

Figure 6. Gate pulses at no load

It can be observed that the gate pulses are switched at the power frequency of 50Hz. Considerable dead time is given between the turn ON of two gate pulses which makes is a QSI.

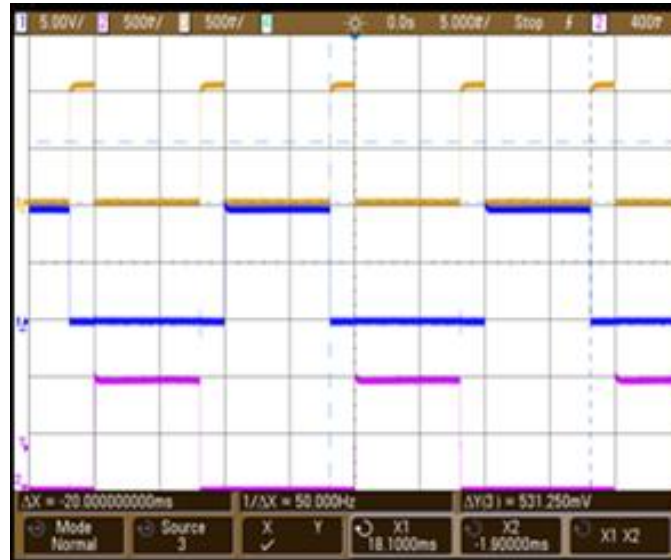

Figure 7. Gate pulses at full load

Output voltage and current waveforms are shown in figure 8 and figure 9 for mains and inverter mode respectively.

In the presence of utility power, pure sinusoidal voltage is applied to the load and the voltage becomes modified square wave as soon as the mains power is cut off, which can be observed in figure 9.

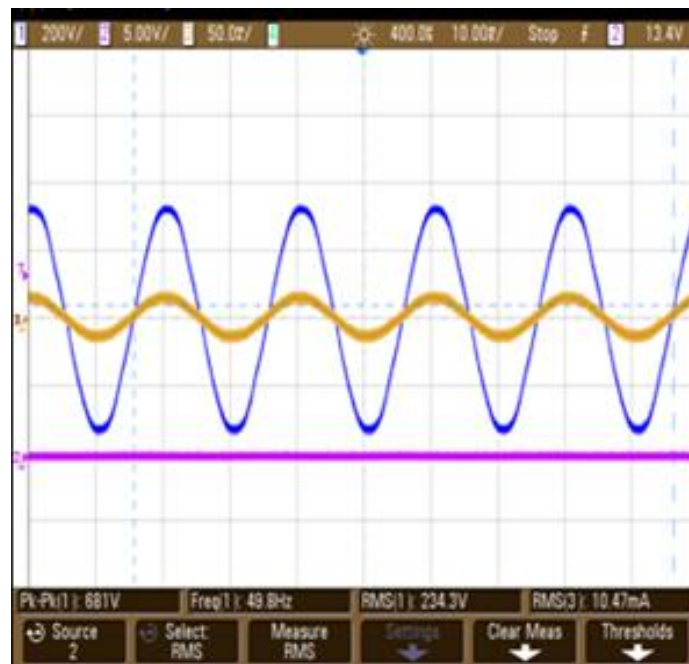

Figure 8. Output voltage and current waveforms during mains mode for resistive load



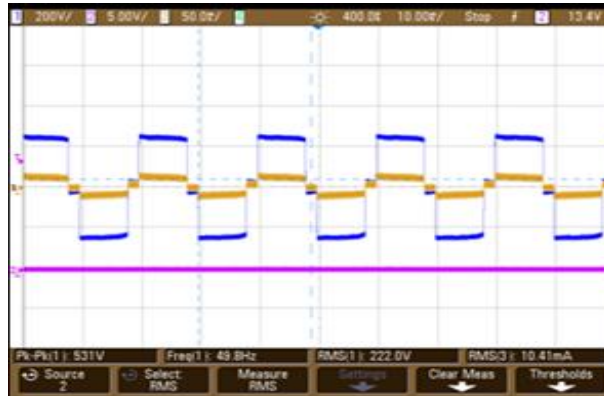

Figure 9. Output voltage and current waveforms during inverter mode for resistive load

**TEST REPORT**

**TABLE 2: TEST REPORT OF QSI**

AVR TEST			
	Mean	LSL	USL
Mains to inverter changeover at low voltage	172	167	177
Inverter to main recovery at low voltage	187	185	193
Mains to inverter changeover at high voltage	270	265	275
Inverter to main recovery at high voltage	260	252	265
LOAD TEST			
Mains mode 60W resistive load	No overload trip		
Mains mode 100W resistive load	Overload LED ON		
Charger output voltage	13.8	13.2	14.4
INVERTER TEST			
No load output voltage	230V	220V	258V
Frequency of output	49.5Hz	49Hz	50Hz
60W resistive load output	220V	210V	230V
Connect 60W resistive load	No overload trip		
Connect 100W resistive load	Unit turn off with overload indication		
Output waveform on battery	Quasi square wave		
End of discharge	10.5V	10.2V	10.7V
Back up time	55 min with 60W load		
DISPLAY INDICATION			
Mains mode	Green LED ON		
Battery mode	Red LED ON		
Battery low	Yellow LED ON		
Overload	Blue LED ON		



## **CONCLUSIONS**

In this paper, most of the efforts are concentrated towards power circuit design and transformer design. The entire inverter unit is controlled by the microcontroller atmega88. Proper care has been taken on selecting the rating of components. In view of this, a hands on experience about certain packages designed by Atmel and International Rectifier which helps the user to design and selection of power stacks.

This paper is a stepping stone to a cheaper and efficient modified square wave inverter, by using the data collected in this work as well as the schematics and recommendations the product produced here can be improved upon. The designed 40W inverter seems to be a promising unit for the elevator illumination application.

## **REFERENCES**

- [1] K. Wang, F. C. Lee and W. Dong, "A New Soft-Switched Quasi-Single-Stage (QSS) Bidirectional Inverter/Charger", *IEEE IAS Annual Meeting*, 1999:2031-2038
- [2] J. Appelbaum, D. Gabbay, "Stepped Sinewave Inverter", *IEEE Trans. on Aerospace and Electronic Systems*, Vol. AES-20, No. 6, pp. 754-760, 1984.
- [3] Surachet Bumrungkeeree, and I. Boonyaroonale, "Push-Pull Dc/Ac Inverter for Large Electroluminescent Lamp". 0-7803-7761-3/031 82003 IEEE.
- [4] Mizhi Zhang, "Efficiency based Evaluation on Inverter topologies with soft switching Techniques" 1-4244-0038-4 2006 IEEE CCECE/CCGEI, Ottawa,2006.
- [5] Atmel corporation atmega88 microcontroller datasheet.
- [6] L.Umanand and S.R.Bhat "Design of Magnetic Components for Switched Mode Power Converters", first edition, 2009, IISC Bengaluru
- [7] Ahmet Kayabasi, Ramazan Akkaya. The Design and Implementation of a Microcontroller- Based Single Phase On-Line Uninterrupted Power Supply With Power Factor Correction.
- [8] M H Rashid "Power Electronics Circuits, Devices, and Applications" second edition, Fellow IEE professor of Electrical Engineering Purdue University Fort Wayne.