



COMPARATIVE STUDY OF DC-DC CONVERTERS FOR RECTIFIER POWER FACTOR CONTROL

Neha R. Naik¹, Dr. H. G. Virani²

1(Electronics & Telecommunication Engineering, Goa College of Engineering, India)

2(Electronics & Telecommunication Engineering, Goa College of Engineering, India)

ABSTRACT

Majority of the applications involving electronic circuitry require a regulated DC supply. Since AC supplies are more commonly available, a suitable AC-DC converter becomes mandatory for such applications. . The input stage of AC-DC converter comprises of a full-bridge rectifier followed by a large filter capacitor. The input current of such a rectifier circuit comprises of large discontinuous peak current pulses that result in high input current harmonic distortion. Thus the power factor is poor.

An active approach is the most effective way to correct power factor of electronic supplies. Here, different Active PFC DC-DC converters (Buck, Boost, Buck-Boost, Cuk and Sepic)are placed between the bridge rectifier and the load. The converter tries to maintain a constant DC output bus voltage and draws a current that is in phase with and at the same frequency as the line voltage.

In this paper,different types of dc-dc converter topologies in continuous conduction mode (CCM) are studied and a comparative analysis based on simulation results of various DC-DC converters (Buck, Boost, Buck-Boost, Cuk and Sepic)is presented. The PI controller is used to reshape the input current. Simulation studies have been carried out usingMATLAB/SIMULINK.

Keywords – Buck, Boost, Buck-Boost, CCM,Power Factor.

I. INTRODUCTION

The input stage of AC-DC converter comprises of a full-bridge rectifier followed by a large filter capacitor. The input current of such a rectifier circuit comprises of large discontinuous peak current pulses that result in high input current harmonic distortion. The high distortion of the input current occurs due to the fact that the diode rectifiers conduct only for a short period. This period corresponds to the time when the mains instantaneous voltage is greater than the capacitor voltage. Since the instantaneous mains voltage is greater than the capacitor voltage only for very short periods of time, when the capacitor is fully charged, large current pulses are drawn from the line during this short period of time. Thus the power factor is poor.

Power factor is defined as the cosine of the angle between voltage and current in an AC circuit. Total Electrical Power = Voltage across the element * current through the element = $V * I$. This is called apparent power, denoted by 'S' and its unit is VA (Volt Amp). A fraction of this total electrical power which

does our useful work is called as active power or true power, denoted by 'P'. Its unit is watt. $P = \text{Active power} = S \cdot \cos\phi$ The other fraction of power is called reactive power. Reactive is required for the active work to be done, denoted by 'Q'. $Q = \text{Reactive power} = S \cdot \sin\phi$ and its unit is VAR (Volt Amp Reactive).

To help understand this better all these power are represented in the form of triangle.

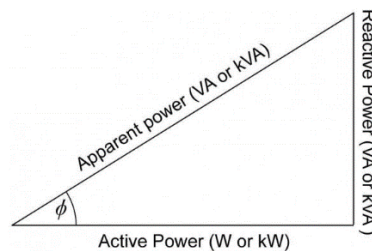

Fig. 1.1 Power Factor Triangle

Mathematically, $S^2 = P^2 + Q^2$ and electrical power factor is $pf = \cos\phi = P/S$.

Power factor (*pf*) gives the measure of quality of a circuit. If the *pf* is unity, the entire power drawn from the source is given to the load. However if the *pf* is low, the input source should be rated for a much higher power than required by the load. This would result in higher line losses resulting in lower efficiency.

II. UNITY POWER FACTOR CONVERTER

The rectifier-capacitor filter circuit is the most popular for obtaining a DC voltage from the AC mains.

However, the input current is of pulsed nature and as a result the power factor is very poor. To improve the power factor, DC-DC converters can be used as shown in Fig. 2.1(a). The power semiconductor switch of the converters is controlled in such a manner that the input current is in phase with the rectified source voltage to achieve unity power factor operation. The rectified source voltage that appears at the input to the converter is shown in Fig. 2.1(b). The requirement for the input current of the converter is also shown. As shown in Fig. 2.1(b), the input current of converter should be in phase with the input voltage to achieve unity power factor.

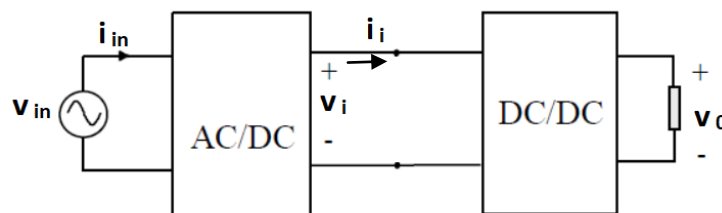

Fig. 2.1(a) DC-DC Converter used as power factor improvement circuit

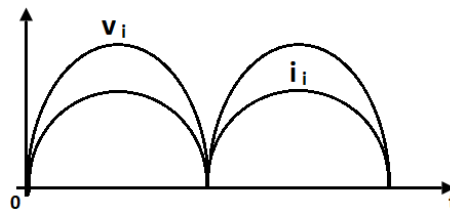

Fig. 2.1(b) Required input current for unity power factor

The control block diagram of the converter for unity power factor operation is shown in Fig. 2.2. The objective of the controller is to control the input current of the converter. The input current i_i of the converter is fed back and compared with the reference i_{ref} that has a rectified sinusoidal wave shape such that it is in phase with the converter input voltage v_i . The error is passed to a PI controller. PI controller output is compared with saw tooth signal to generate the PWM signal. The generated PWM is passed through the power switch drive circuit to turn ON and OFF the converter switch. The PI controller make sure that the error at its input is zero, which implies that i_i tracks i_{ref} .

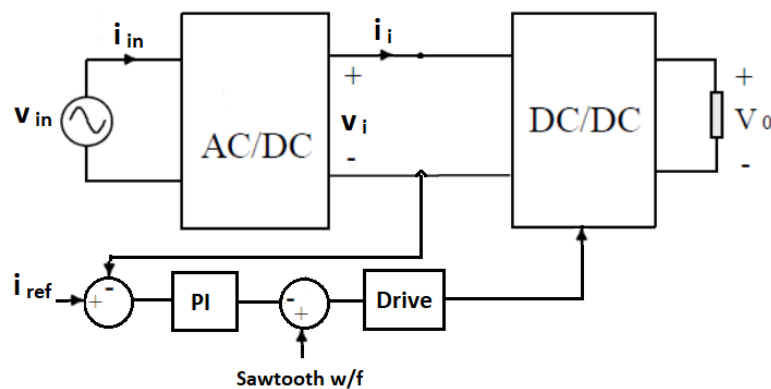

Fig. 2.2 Block diagram of the control scheme for power factor improvement

III. REFERENCE CURRENT GENERATION

The generation of a reference current, i_{ref} is important in this topology. i_{ref} should have a wave shape that follows the wave shape of the rectified source voltage. The amplitude of i_{ref} is determined by the output power requirement. Consider the input source voltage:

$$v_{in} = V_m \sin(\omega t) \tag{1}$$

This v_{in} is normalized and rectified to obtain:

$$v_n = \frac{v_{in}}{V_m} = \sin(\omega t) \tag{2}$$

Equation (2), defines the reference current wave shape. The amplitude is determined by the output power requirement. If P_0 is the output power, then:

$$P_0 = V_0 I_0 \tag{3}$$

Assuming 100% efficiency of the converter:



$$V_{irms} I_{irms} = P_0 = V_0 I_0 \quad (4)$$

From equation (4):

$$I_{irms} = \frac{P_0}{V_{irms}} = \frac{V_0 I_0}{V_{irms}} \quad (5)$$

Equation (5) determines the amplitude of the reference current wave shape. From equations (3) and (5), the reference current is given as:

$$i_{iref} = \sqrt{2} I_{irms} \sin(\omega t) = \sqrt{2} \frac{V_0 I_0}{V_{irms}} \sin(\omega t) \quad (6)$$

IV.MODELLING OF DC-DC CONVERTERS

In order to design controller we need to have knowledge of DC-DC converter in mathematical form and this is called Dynamic Modelling.

Dynamic Model: - State space representation

-Transfer function representation

When we do dynamic modelling we arrive at differential equations which is basically State space representation and from state space representation we obtain transfer function representation.

State space representation:

State space representation is given in the form:

$$\dot{x} = Ax + Bu \quad (7)$$

$$y = Cx + Du \quad (8)$$

For any system the mathematical model can be represented in the standard form of equations (7) and (8). Where x is the $n \times 1$ state vectors which comprises the state variables for a system of order n . A is $n \times n$ system parameter matrix which consist of the system constants. The B matrix is the $n \times m$ input matrix which weights the direct input excitation for state variables. U is the $m \times 1$ input vector for m input excitations. Y is the $p \times 1$ output vector for p outputs from the system. C is a $p \times n$ output matrix and D is a $p \times m$ feed forward matrix.

Transfer function representation:

Taking the Laplace transform of the state equation and from the definition of the transfer function, the initial conditions are zero. So we get:

$$sX(s) = AX(s) + BU(s) \quad \text{or} \quad (sI - A)X(s) = BU(s) \quad (9)$$

Pre multiplying both sides of equation (9) by $(sI - A)^{-1}$, one obtains:

$$X(s) = (sI - A)^{-1}BU(s) \quad (10)$$

From the output equation of the state space representation, one obtains:



$$Y(s) = CX(s) + DU(s) \tag{11}$$

The transfer function from the state space representation is given as:

$$G(s) = \frac{Y(s)}{U(s)} = C(sI - A)^{-1}B + D \tag{12}$$

DC-DC converter have only one nonlinear element i.e. switch. It has two states: ON and OFF. Due to this reason classic control theory for designing controller cannot be applied directly some type of averaging model is required to obtain the mathematical representation of different DC-DC converters and that method is called circuit averaging.

Circuit Averaging:

The circuit averaging method is explained in the following steps:

Step 1: Large signal Model:

$$\dot{x} = A_1x + B_1u; y = C_1x + D_1u \tag{13}$$

$$\dot{x} = A_2x + B_2u; y = C_2x + D_2u \tag{14}$$

Step 2: Average Large-Signal Model:

$$\dot{x} = Ax + Bu; y = Cx + Du \tag{15}$$

where $A = A_1d + A_2(1 - d)$; $B = B_1d + B_2(1 - d)$; $C = C_1d + C_2(1 - d)$; $D = D_1d + D_2(1 - d)$

Step 3: Steady-State Model

Under steady state or equilibrium conditions: $\dot{x} = 0$; $x = X$; $u = U$; $y = Y$

For the steady-state conditions, equation (15) can be written as:

$$0 = AX + BU; Y = CX + DU \tag{16}$$

Step 4: Small signal Model:

$$\dot{X} + \hat{x} = [A_1(D + \hat{d}) + A_2(1 - D - \hat{d})](X + \hat{x}) + [B_1(D + \hat{d}) + B_2(1 - D - \hat{d})](U + \hat{u})$$

$$Y + \hat{y} = [C_1(D + \hat{d}) + C_2(1 - D - \hat{d})](X + \hat{x}) + [D_1(D + \hat{d}) + D_2(1 - D - \hat{d})](U + \hat{u})$$

The above equations can be expanded. Terms containing $\hat{x}.\hat{d}$ and $\hat{d}.\hat{u}$ can be neglected and the steady state terms $AX + BU = 0$. Thus, the resultant small signal model is given as:

$$\dot{\hat{x}} = A\hat{x} + B\hat{u}_n$$



$$\hat{y} = C\hat{x} + D\hat{u}_n \tag{17}$$

Where

$$A = A_1D + A_2(1 - D); \quad B = [B_1D + B_2(1 - D) \quad (A_1 - A_2)X + (B_1 - B_2)U]$$

$$\hat{u}_n = \begin{bmatrix} \hat{u} \\ \hat{d} \end{bmatrix}$$

$$C = C_1D + C_2(1 - D); \quad D = [D_1D + D_2(1 - D) \quad (C_1 - C_2)X + (D_1 - D_2)U]$$

V. RESULT

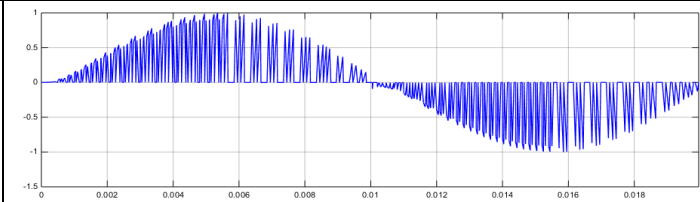
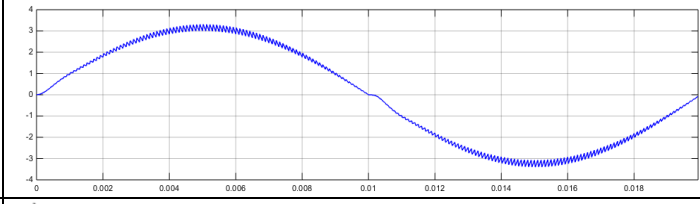
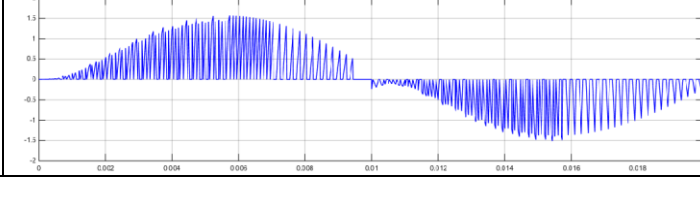
DC-DC Converter topologies	Improved input current w/f	Power Factor
Buck		0.654
Boost		0.925
Buck-Boost		0.535

VI. CONCLUSION

The power factor correction circuits have been simulated in MATLAB/SIMULINK. In this paper the comparative study of the Buck, Boost and Buck-Boost topologies for active power factor correction in AC-DC converters has been carried out. Mathematical modelling of all three converters has been done and controller tuning is done by Nicholas Ziegler method. From the results, it is found that the Boost Converter topology for Active power factor correction is the best among the three topologies as it improves power factor closer to unity.



REFERENCES

Papers:

- [1] Abhinaya Venkatesan, Aiswarya Mohan, Gayathri. K, R.Seyezhai, comparative study of active power factor correction in ac-dc.converters, International Journal of Electrical, Electronics and Data Communication, ISSN (p): 2320-2084.
- [2] A K M Kamrul Hasan, MdFaruque Hossain, Comparison of PFC Circuit Topologies, American Journal of Engineering Research (AJER) e-ISSN: 2320-0847 p-ISSN : 2320-0936 Volume-5, Issue-7, pp-133-136.
- [3] Daniel ALBU, Nicolae DRĂGHICIU, Gabriela TONȚ and Dan George TONȚ, Converters with Power Factor Correction, ACTA ELECTROTEHNICA.
- [4] Huai Wei and Issa Batarseh, Comparison of Basic Converter Topologies for Power Factor Correction, Proceedings IEEE Southeastcon '98 'Engineering for a New Era'.
- [5] Sujata Powniker and Sachin Shelar, Development of Active Power Factor Correction Controller Using Boost Converter, 2016 IEEE International WIE Conference on Electrical and Computer Engineering (WIECON-ECE)
- [6] A. K. Mishra, M. K. Pathak and S. Das, Isolated converter topologies for power factor correction, 2011 International Conference on Energy, Automation and Signal.
- [7] Yamamoto, K Matsui, and M. Matsuo, A comparison of various DC-DC converters and their application to power factor correction, Proceedings of the Power Conversion Conference-Osaka 2002 (Cat. No. 02TH8579)

Books:

- [6] Power Electronics Essentials and Applications by L Ulmanand.
- [7] Fundamentals of Power Electronics 2nd edition by Robert W. Erickson.
- [8] Power Electronics Circuits, Devices and Applications by M .H. Rashid.