



GPS BASED E-UNIFORM USING SOLAR PANEL FOR SOLDIERS

B.Amritha¹, P.Vinitha², S.Swathi³, P.Roobini⁴

EEE Department, University College of Engineering Arni (India)

ABSTRACT

Solar based E-Uniform gives better protection to the soldiers who work in extreme weather conditions. Solar Panels are used to power up the internal circuitry of the E-uniform. The energy is stored by using a 12V DC lead acid rechargeable battery. A conventional battery can also be used as charging unit. LPC2148 micro controller controls all the functions. A voltage sampler is interfaced with the system using ADC to get the voltage generated from battery as a display on a 16X2 LCD. In this paper we have designed an E-Uniform which gives better protection to the soldiers who work in extreme weather conditions. This Uniform will facilitate the soldier to work in any kind of environment.

A jacket is mounted with the circuit which is operated in summer mode and winter mode. By selecting the mode of operation, we operate the H-Bridge IC so that it can drive body heater/cooler. The heater/cooler in turn will help us to provide chilling or warming effect inside the uniform which helps the soldier to bear any kind of external environment. The metal sensor detects the metal like bomb and intimates the soldier with a buzzer indication. This Uniform will make the soldier to work in any kind of environment. So, he can work efficiently without heat stress or cold stress.

I INTRODUCTION

Soldiers are the Army's most important resource. Soldiers play a crucial role in protecting one's country. The term soldiers include service men and women from the Army, Air Force, Navy and Marines. They are always responsible for exercising the duty in extreme weather conditions throughout the year. While providing security to the nation, they may face troubles in extreme hot/cold weather conditions. Both very hot and cold temperatures could be dangerous to health thereby reducing their efficiency. In this paper we have made an attempt to design an E-Uniform which gives better protection to the soldiers who are working in extreme weather conditions. This system gives two modes summer mode and winter mode .

II BLOCK DIAGRAM

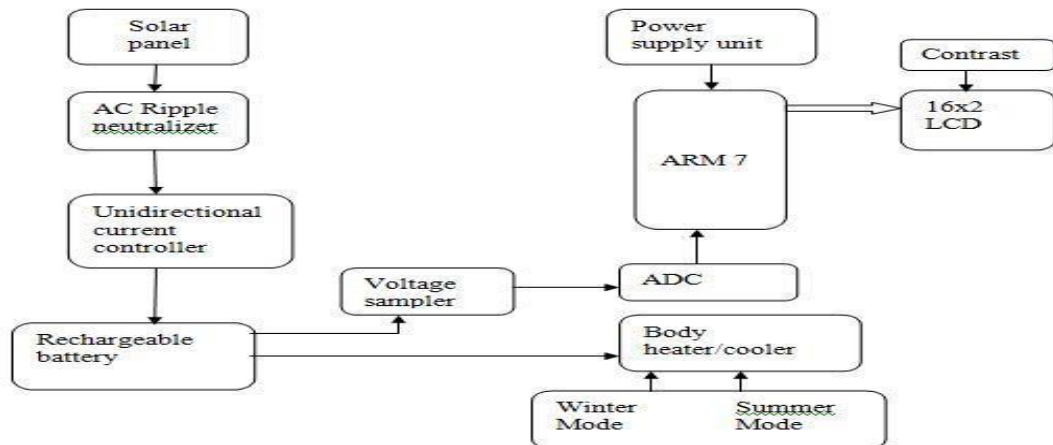

III WORKING

In this paper solar panels are used for charging a Lead Acid Battery , a peltier thermoelectric device which when connected to battery generates cooling effect on one side and heat is dissipated on other side through heat sink. Here we are using Micro controller (LPC2148) allows dynamic and faster control. Liquid crystal display (LCD) makes the system user- friendly. Here we are using LCD Display for displaying the values of present and maximum voltage values which are present in the rechargeable battery. The project is operated in two modes summer mode and winter mode. By selecting the mode of operation such that it can drive body heater/cooler. The heater/cooler in turn will help us to provide chilling or warming effect inside the uniform which helps the soldier to bear to any kind of external environment and he can work efficiently without heat stress or cold stress.Soldiers work in different atmosphere and always moving so its easy and efficient to use solar power for operation. Here we are using AC ripple neutralizer which is nothing but voltage stabilizer. It will remove ripple from solar power. This power will then given to unidirectional current controller. Unidirectional current controller controls only positive and not negative supply voltage. Now this will forwarded to rechargeable battery. It is a Lead Acid Battery.Here we are using inbuilt ADC of LPC2148.The signal then given to ADC of controller. Here sampling takes place which then give us output.LCD display is used to display present voltage and maximum voltage of battery on screen. Peltier plate is present in jacket which will do cooling and heating mechanism.

Flow chart:-

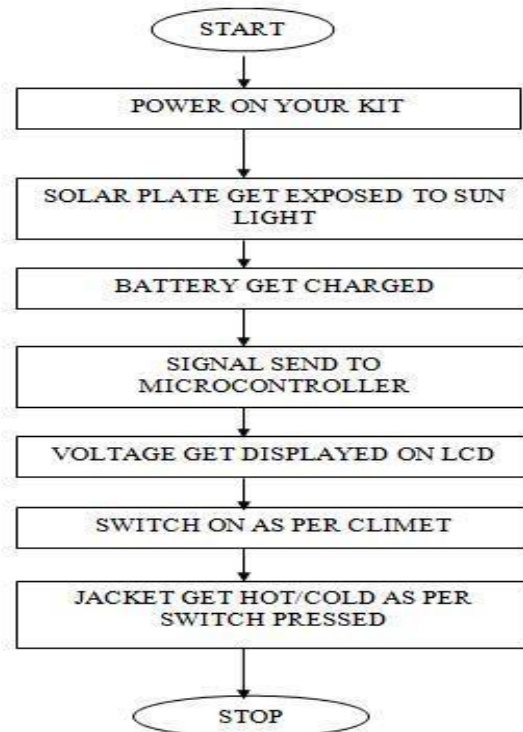

IV CONCLUSIONS

Officers are one of the imperative components in a nation. Since they are the strengths who secure our nation day and night living behind rest and rest. In this manner it is our obligation to ensure them. Same is the centrality of this undertaking. So here outline an E Uniform which gives better insurance to the warriors who are working in compelling climate conditions. This venture is worked in two modes summer mode and winter mode. In the event that the climate condition is excessively hot then the cooling framework will worked and in the event that it is excessively cool then the warming framework will worked..

REFERENCES

- [1]. Adarsh K S, Arun Dinesh, Jyothy Elizebeth D: "E-Uniform For Soldier's Who Work At Extreme Temperature Regions", International Journal of Engineering Research and General Science Volume 3, Issue 3, May-June, 2015,, pp. 993 – 998.
- [2]. Muhammad Ali Mazidi, Rolin D. McKinlay, Danny Causey PIC Microcontroller and Embedded Systems: Using Assembly and C for PIC18