

# DESIGN OF ZIGZAG CONNECTED AUTO - TRANSFORMER BASED 24-PULSE AC/DC CONVERTOR

**Aniket Anandrao Mane**

*Electrical Department, NanaSaheb,  
Mahadik College Of Engineering, (India)*

## **ABSTRACT**

*This paper deals with the design of zigzag connected auto-transformer based ac/dc converter. To realize the zigzag connection in transformer, there should be two identical secondary winding sections per phase for each primary winding. For auto-transformer with zigzag connection, windings are connected in series subtractive polarity for all phases. As the third harmonic components of phase voltages and currents are co-phaser in nature, hence the resultant third harmonic emf component between all the phases to neutral becomes zero. So current harmonics are reduced and power quality at ac mains is improved to meet IEEE-519 Standard requirements at varying loads[4]. A 24-Pulse zigzag connected auto-transformer based ac/dc converter is designed, modeled and simulated in MATLAB for non-isolated varying loads. Three models of 6-pulse, 12-pulse and 24-pulse ac/dc are compared on their performance with power quality indices on input ac mains current and dc bus voltage for non-isolated varying loads. The winding design, convertor models, their analysis and simulation results for 6-pulse, 12-pulse and 24-pulse ac/dc convertor are presented in this paper for varying loads.*

**Keywords**–zigzag connection, 24-pulse, ac/dc convertors, autotransformer.

## **I. INTRODUCTION**

The power system is a large, non-linear and complex network. It contains generators, transformers, convertors and transmission lines etc. To use all these components in efficiently and economically, the power quality has to be maintained. This paper deals with the improvement of power quality in ac mains to meet IEEE-519 Standard requirements. To achieve current harmonic reduction to improve power quality in ac mains a zigzag connected auto-transformer based 24-pulse ac/dc converter is designed.

The Conventional rectifiers are created using diodes and thyristors, has the following issue such as reduction in power quality due to current harmonic injection. The current harmonic injection produces increased losses in the power system and utility components. So utility components suffers from additional temperature rise due to the current harmonics. More disadvantages of conventional rectifiers are low efficiency and in need of large size of AC and DC filters. To get negligible ripples in the output voltages of Conventional rectifier at 50 Hz or 60 Hz

frequency, the size of filters required is large. This makes the power supply inefficient, bulky and weighty. However some applications should requires precise power quality which leads to use of higher pulse ac/da convertor system to meet IEEE-519 Standard requirements. So to reduce the above disadvantage a zigzag connected auto-transformer based 24-pulse ac/dc converter is proposed. The zigzag connected auto-transformer based 24-pulse ac/dc converter is primarily focuses on harmonic reduction and commonly used diode rectifiers are used for conversion process. A serious disadvantage is, the rectifiers can inject giant harmonic distortion within the input currents. Clearly a 12-pulse device is employed for reducing the harmonics injected; however it additionally includes the  $(12n \pm 1)$  harmonics within the input currents. So as to scale back the harmonics within the input current, the 24- pulse rectifier is projected .Wherever it'll reduce the lower order harmonics like 5th, 7th, 11th and 13th.and lowers the harmonics.

With this in view, a 24-pulse AC-DC converter is designed and developed using zigzag connected auto-transformer. In this paper, a zigzag autotransformer is proposed to produce four sets of phase staggered three-phase voltages. The secondary windings of unlike phases of different single-phase transformers are interconnected to form zigzag arrangement. The proposed autotransformer is capable of feeding four 6-pulse diode bridges, which are connected in parallel. This parallel connection produces a 24-pulse AC-DC converter configuration. A detailed design of the 24-pulse rectifier system is carried out to study the behavior of the proposed AC-DC converter under varying loads. The designed AC-DC converter system is modeled and simulated in MATLAB and its performance is evaluated to demonstrate power quality improvement at AC mains. The prototypes of 12-pulse and proposed 24-pulse AC-DC converters are developed in a laboratory to validate the developed models and their design.

## II. PROPOSED ZIGZAG CONNECTED AUTOTRANSFORMER AC-DC CONVERTERS

### II.1 – Design of 6-pulse and 12-pulse zigzag connected autotransformer based ac-dc converter -

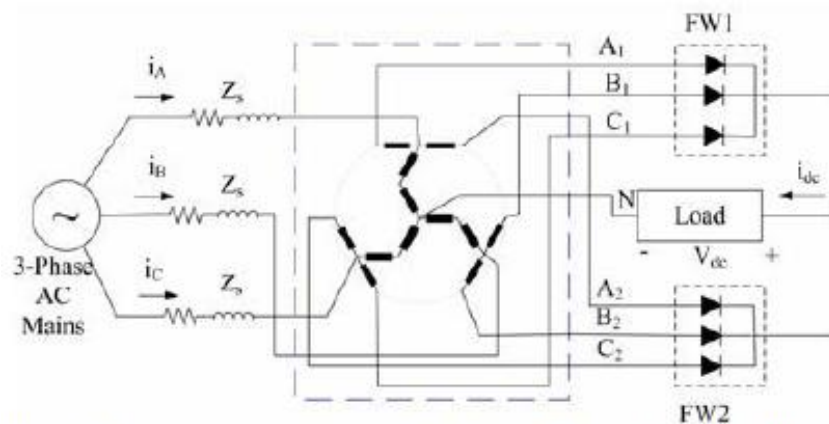

Fig. 2: Proposed zigzag autotransformer based 6-pulse full-wave AC-DC converter.

Fig. 2 shows the proposed 6-pulse full-wave AC-DC converter. In this configuration zigzag connected autotransformer is used. The design is described as follows. A. Design of Zigzag Autotransformer Suitable for 6-Pulse Full-Wave AC-DC Converter Fig. 2 shows the schematic of the proposed zigzag connected autotransformer winding arrangement and its connection to two full-wave converters, FW1 and FW2. Two full-wave converters FW1 and FW2 are connected to two sets of three-phases at (A1, B1, C1) and (A2, B2, C2) respectively. Fig. 2 depicts the graphical representation of the autotransformer windings and angular position of various voltage phasors. Two sets of three phase voltages are (VA1, VB1, VC1) and (VA2, VB2, VC2). These sets are displaced by 60° from each other and at +30° and -30° respectively from AC mains voltage VA

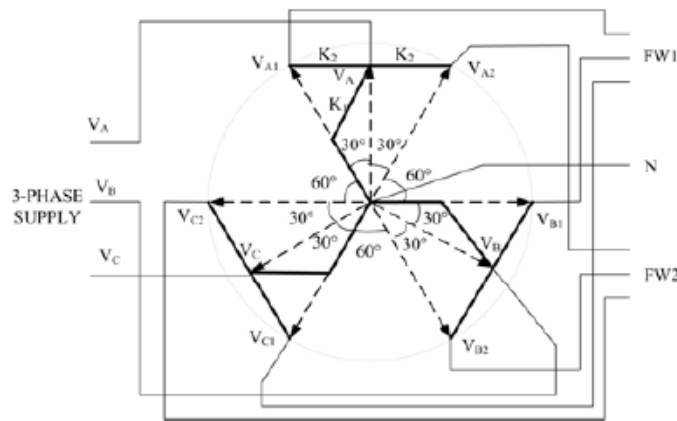

Fig. 3: Winding arrangement and phasor diagram of transformer for 6-pulse non-isolated full-wave AC-DC converter.

Design of 12-pulse zigzag connected autotransformer based ac-dc converter- For the design of zigzag connected auto-transformer based 12-pulse ac/dc converter, we have to give three winding sections per phase. Which are connected to the three phases in zigzag manner to eliminate the effect of third harmonic component in all the phases.

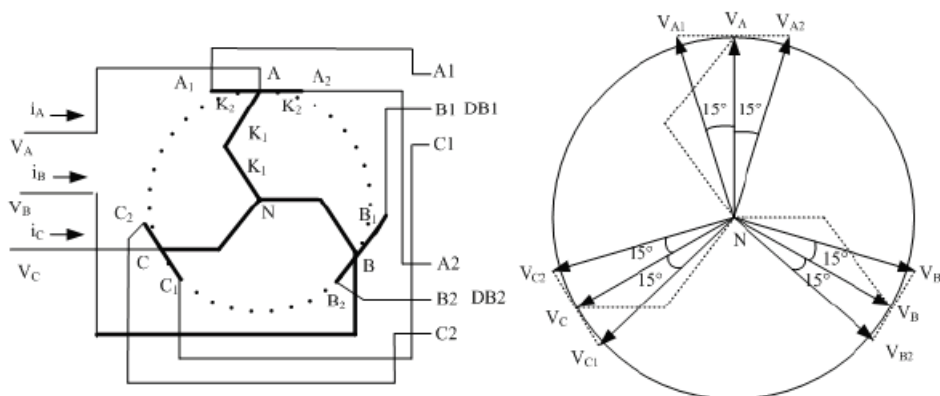

Figure shows a 12-pulse AC-DC converter. This topology uses a zigzag-transformer that feeds two six-pulse diode bridge converters, which are connected on the DC side by inter-phase transformers. The end terminals of one winding section from all the phases are connected to the 6-pulse diode bridge rectifier. These two 6-pulse diode bridge rectifiers are connected in parallel to build a 12-pulse zigzag connected auto-transformer based ac/dc converter, which gives the reduced total harmonic distortion than the 6-pulse zigzag connected auto-transformer based ac/dc converter. As shown in figure the end terminals of one winding section from all the phases are connected to the 6-pulse diode bridge rectifiers. The two end terminals of winding section introduce a phase staggering angle of 15 degree with the individual phase voltage as shown. The phase staggering angle depends on the number of winding turns that is on the value of constants from  $k_1$  to  $k_{10}$ .

The number of turns for every winding are determined as a function of the phase voltage,  $V_A (=V)$ . These voltages, as marked in Fig.3, are expressed by following relationships. Consider the set of three phase supply voltages as

$$V_A = V \angle 0^\circ, V_B = V \angle -120^\circ, V_C = V \angle 120^\circ$$

$$|V_A| = V_R = 1.1547 * V_A$$

The required voltages for the converters I (FW1) are :

$$V_{A1} = V_R \angle 30^\circ, V_{B1} = V_R \angle 90^\circ, V_{C1} = V_R \angle 150^\circ$$

The required voltages for the converters II (FW2) are:

$$V_{A2} = V_R \angle -30^\circ, V_{B2} = V_R \angle -150^\circ, V_{C2} = V_R \angle -90^\circ$$

The values of constants  $K_1$  to  $K_3$  marked in Fig. 3, determine the winding voltages as a fraction of phase windings turns. The value of output voltage phasors can also be expressed in terms of input phase and line voltages as:

$$V_{A1} = K_1 * V_{AB} - K_1 * V_{CA} - K_2 * V_{BC} \quad - (1)$$

$$V_{A2} = K_1 * V_{AB} - K_1 * V_{CA} - K_2 * V_{BC} \quad - (2)$$

$$V_{C2} = V_C - K_2 * V_{AB} \quad - (3)$$

Eqns. (5-7) give the values of constants  $K_1$  and  $K_2$  for desired phase shift as

$$K_1 = 0.322 \text{ and } K_2 = 0.15 \quad - (4)$$

## 2.2 – Design of 24-pulse zigzag connected autotransformer based ac-dc converter –

The zigzag autotransformer winding arrangement for a 24-pulse AC-DC converter is shown in Figure and its connection along with a phasor diagram. The four sets of output three-phase voltages produced are displaced at an angle of  $15^\circ$ . Two of these sets are displaced at an angle of  $\pm 7.5^\circ$  from input phase voltage while the remaining two sets are displaced by  $\pm 22.5^\circ$ .

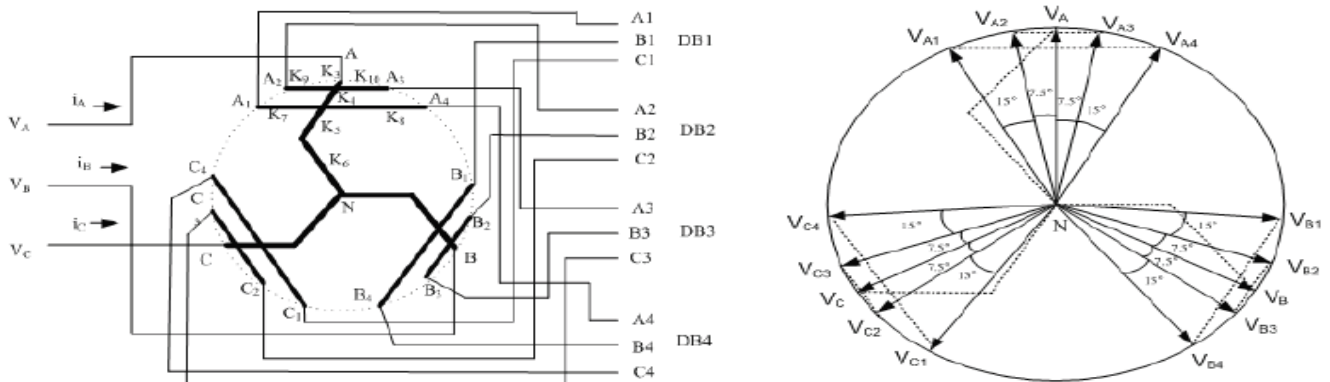

Zigzag autotransformer winding arrangement for 24-pulse AC-DC con

Figs. 3(b) and 3(c) show the schematic of the zigzag arrangement and its graphical representation depicting the angular position of various phasors. The number of turns for every winding is determined as a function of the input phase voltage,  $V_A$ . These winding voltages, as marked in Figs. 3b and 3c, are expressed by the following relationships. Consider that the input phase voltage is  $V_A (=V_{AC}/\sqrt{3})$  and four sets of three-phase voltages fed to each bridge DB1 to DB4 are  $V_{A1}, V_{B1}, V_{C1}; V_{A2}, V_{B2}, V_{C2}; V_{A3}, V_{B3}, V_{C3};$  and  $V_{A4}, V_{B4}, V_{C4}$  respectively. The four sets of required voltages for the converters DB1 to DB4 are:

$$\begin{aligned} V_{A1} &= V_S \angle 22.5^\circ, V_{B1} = V_S \angle 97.5^\circ, V_{C1} = V_S \angle -217.5^\circ, \\ V_{A2} &= V_S \angle 7.5^\circ, V_{B2} = V_S \angle -112.5^\circ, V_{C2} = V_S \angle -232.5^\circ, \\ V_{A3} &= V_S \angle -7.5^\circ, V_{B3} = V_S \angle -127.5^\circ, V_{C3} = V_S \angle -247.5^\circ, \\ V_{A4} &= V_S \angle -22.5^\circ, V_{B4} = V_S \angle -142.5^\circ, V_{C4} = V_S \angle -262.5^\circ, \end{aligned}$$

The output equations can be given as:

$$\begin{aligned} V_{A1} &= -K_5 V_{CA} + K_6 V_{AB} - K_7 V_{BC} \\ V_{A2} &= -(K_4 + K_5) V_{CA} + K_6 V_{AB} - K_9 V_{BC} \\ V_{A3} &= -(K_4 + K_5) V_{CA} - K_6 V_{AB} - K_{10} V_{BC} \\ V_{A4} &= -K_5 V_{CA} + K_6 V_{AB} + K_{10} V_{BC} \\ K_3 + K_4 + K_5 &= K_6 \end{aligned} \quad - (5)$$

All the above equations give the values of constants  $K_3$  to  $K_{10}$  for desired phase shift as:

$$\begin{aligned} K_3 &= 0.14, K_4 = 0.045, K_5 = 0.216, K_6 = 0.4, \\ K_7 &= 0.13, K_8 = 0.313, K_9 = 0.0059, K_{10} = 0.145 \end{aligned} \quad - (6)$$

The values of these constants  $K_3$  to  $K_{10}$  determine the winding turns as a fraction of input phase voltage. These values are used for the simulation of the proposed 24-pulse ac-dc converter.

### III. MATLAB BASED SIMULATION OF PROPOSED ZIGZAG CONNECTED AUTOTRANSFORMER BASED AC-DC CONVERTER

The proposed 6-pulse, 12-pulse, and 24-pulse non-isolated full-wave AC-DC converters are modeled and simulated in MATLAB environment along with SIMULINK. These full-wave AC-DC converter systems are fed from 450V, 50Hz AC supply. The load connected to the converter is considered of rating of 8kW, 500V DC load. Figure 8 shows the MATLAB model of the 12-pulse full-wave AC-DC converter to improve various power-quality indices and Fig. 9 shows the MATLAB model of the 24-pulse full-wave AC-DC converter to improve various power-quality indices of the autotransformer winding arrangement used. The simulations of the 6-pulse, 12-pulse and 24-pulse full-wave AC-DC converters are also carried out in similar way for same supply and load conditions for comparing their performance.

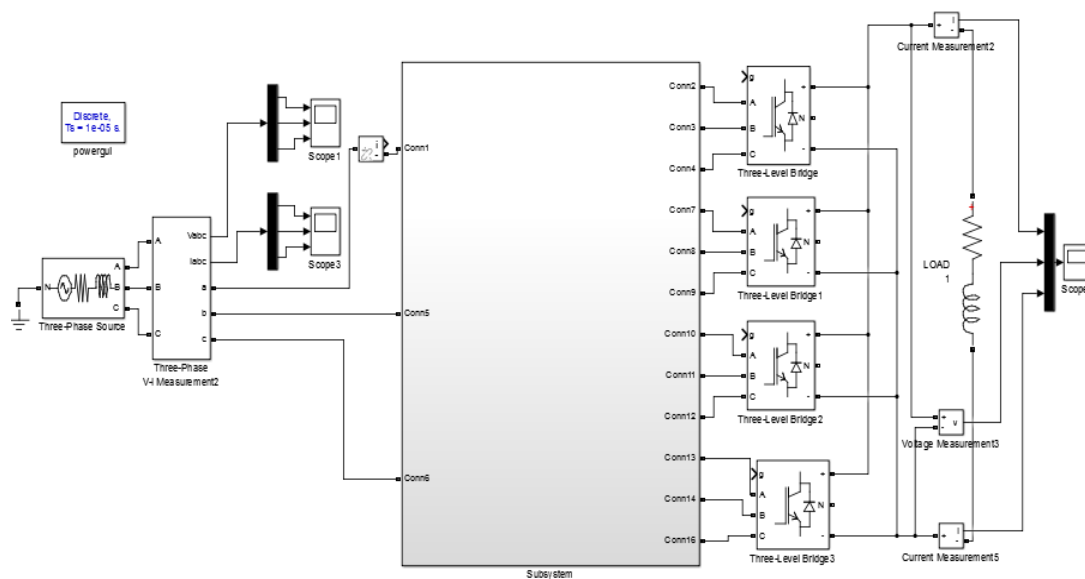

**Fig.4a.**MATLAB model of 24-pulse AC-DC converter

### IV.RESULTS AND ANALYSIS

Sr. No	Zigzag auto-transformer based Converter Configuration	%Load (kw)	%THD Of VA	%THD Of IA	AC Mains Current IA (A)	Distortion Factor	DC Voltage Vdc(V)	Load Current Idc (A)
1	6-pulse	25	27.14	13.43	35.2	0.9911	160	1.4
		50	27.87	13.28	35.8	0.9912	141	2.6
		75	28.89	13.23	36.45	0.9913	128	4.1
		100	29.44	13.22	37.1	0.9913	122	5.2
2	12-Pulse	25	9.32	6.76	11.81	0.9977	572	4.96
		50	9.36	6.00	20.4	0.9982	420	8.4
		75	10.73	6.64	23.3	0.9978	369	9.8
		100	11.79	7.29	25.7	0.9973	304	12.2
3	24-Pulse	25	5.00	5.8	8.72	0.9983	414	4.05
		50	5.74	6.27	11.2	0.9980	361.5	7.2
		75	5.64	6.79	13.27	0.9977	323.3	9.65
		100	5.45	7.26	13.65	0.9973	284	11.25

Comparison of power quality parameters of the different full-wave AC-DC converters

The power quality indices obtained from simulations of 6- pulse, 12-pulse, and 24-pulse AC-DC converters at varying load are given in Table. The waveforms of input current along with supply voltage and output DC voltage and current are shown in Figs. 8-11.

Fig. 8: (a) shows the input AC waveforms with the output DC voltage and current waveforms of six-pulse converter configuration. The current is highly non-sinusoidal and the  $(6k\pm 1)$  harmonics are prevalent which can be seen in Fig. 8(b) that shows input current waveform and its harmonic spectrum. The total harmonic distortion (THD) of AC mains voltage and current at full-load for this six-pulse converter are observed to be 29.44% and 13.22% which is much higher than power quality standard (IEEE-519) requirements of 8%, like the other six-pulse AC-DC converters. However, it may be useful if it used with a passive or active filter to meet power quality requirement

Fig. 9(b) shows the input current waveform and its harmonic spectrum for 12-pulse AC-DC converter. The THD of AC mains voltage and current is observed to be 11.79% and 7.29% and it has dominant 11th and 13th harmonics. The input current has become close to sinusoidal and power factor (PF) has also improved. The current harmonics are 7.29%, so it meets IEEE-519 Standard requirements of power quality.

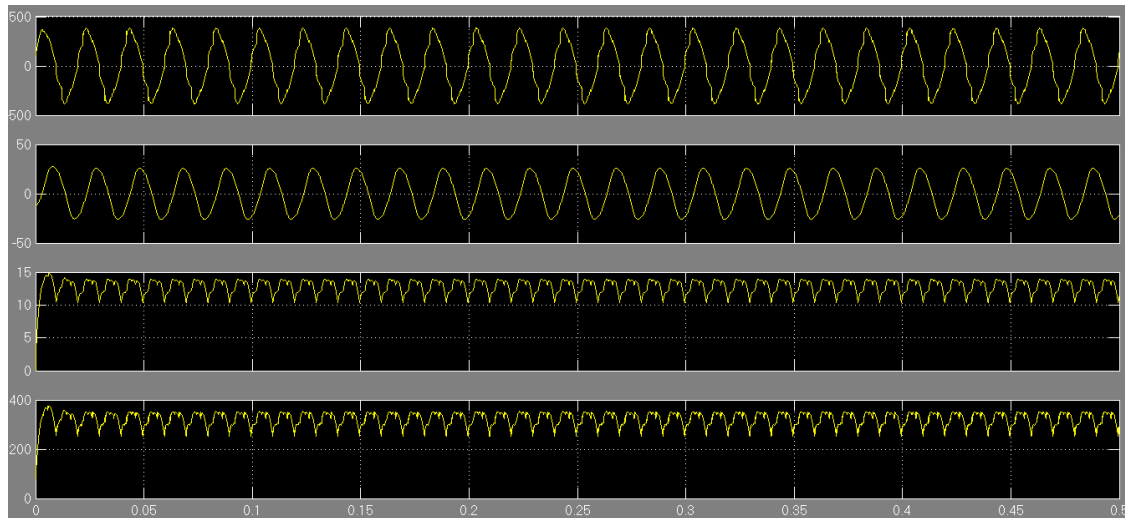
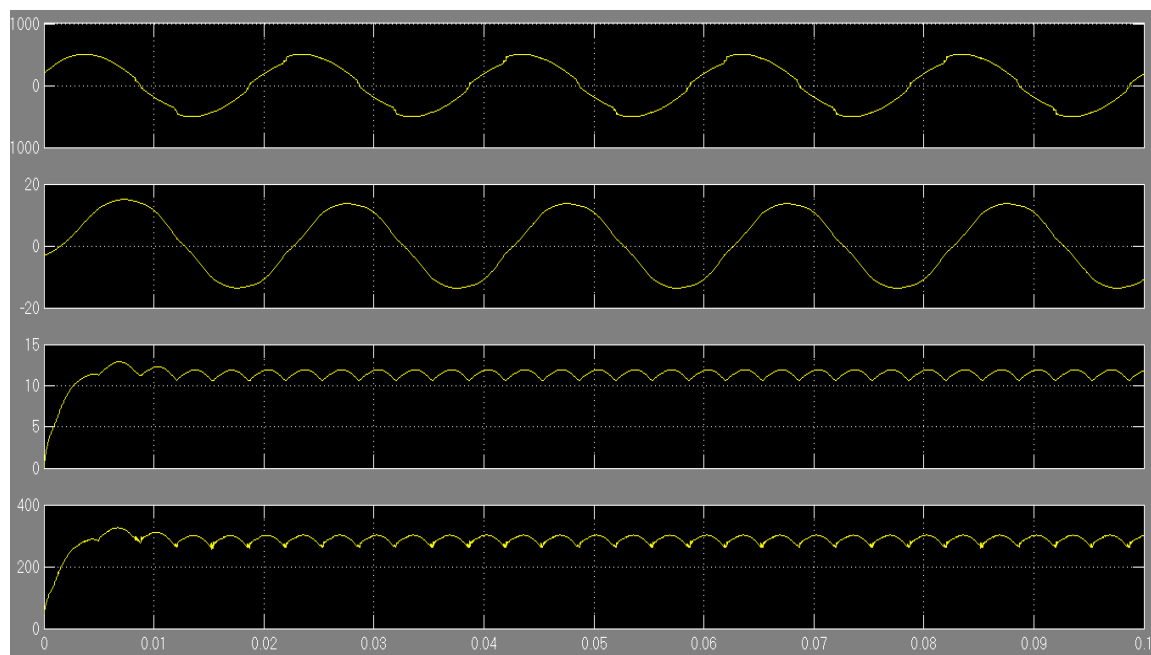

Fig. 11(a) shows the input voltage and current waveforms along with output DC voltage and current waveforms of 24-pulse AC-DC converter. The waveforms of input current as well as output voltage has improved remarkably without employing any filter at front end. The input AC mains current waveform is almost sinusoidal and has dominant 23rd and 25th harmonics as shown in Fig. 11(b). Table 1 depicts that the THD variation of input voltage and current is 5.45% to 7.26% with the load and power factor observed is also good. The variation of THD of AC mains current and power factor with the load for these 6-pulse, 12-pulse, and 24-pulse full-wave non-isolated converter configurations are shown in Figs. 12 and 13 respectively. It clearly shows a remarkable improvement in power quality in the case of 24-pulse AC-DC converter.





The total harmonic distortion of input current is observed to be less than 8% at varying loads and meets IEEE-519 Standard power quality requirements. The output voltage ripple is of order less than 2% and input power factor is improved at varying loads thereby improving power quality at AC mains and output load.

The total harmonic distortion (THD) of AC mains voltage and current at full-load for this six-pulse converter are observed to be 29.44% and 13.22% which is much higher than power quality standard (IEEE-519) requirements of 8%, like the other six-pulse AC-DC converters. The THD of AC mains voltage and current is observed to be 11.79% and 7.29% and it has dominant 11th and 13th harmonics. The THD variation of input voltage and current is 5.45% to 7.26% with the load and power factor observed is also good as shown below the FFT analysis for the total harmonic distortion (THD) of AC mains voltage and current at full-load 12-pulse and 24-pulse zigzag connected auto-transformer based ac/dc converter.

## **V. CONCLUSION**

The zigzag connected autotransformers used for these 6, 12, and 24-pulse full-wave AC-DC converter systems have formed a new class of AC-DC converters. These converters provide balanced outputs voltages for rectification and suits for lower secondary voltage applications. Obtained results have demonstrated that the proposed 12-pulse and 24-pulse full-wave AC-DC converters exhibit a high level performance with clean power characteristics. The total harmonic distortion of input current is observed to be less than 8% at varying loads and meets IEEE-519 Standard power quality requirements in MATLAB designed model. The output voltage ripple is of order less than 2% and input power factor is improved in MATLAB designed model at varying loads thereby improving power quality at AC mains and output load.

## **REFERANCES**

- [1] Bhim Singh and Sanjay Gairola, "zigzag connected auto-transformer based 24-pulse ac/dc converter" Journal of Electrical Engineering Technology Vol.2 pp.235,"2008"
- [2] "D. A. Paice, Wye connected 3 phase to 9 phase autotransformer with a reduced winding currents" , U S Patent No. 6,191,968 B1, Feb. 2001.
- [3] D. W. Owens , Autotransformer for use with multiple phase rectifiers, U S Patent 7049921, May 23, 2006.
- [4] "IEEE recommended practice and requirements for harmonic control in electrical power systems, standard 519-1992 IEEE Inc. New York ,1993."