

SMART EARLY WARNING SYSTEM USED IN WAREHOUSES THROUGH IOT TECHNOLOGY

P.Sivasankaran¹, S.Sruthi Priya², V.Kowsalya³,

D.Hari Hara Shree⁴

¹Ap/Ece, Guide, Sengunthar Engineering College, (India)

^{2,3,4}Student Member/Ece, Sengunthar Engineering College, (India)

ABSTRACT

In order to develop an early warning system to control the storage loss of food grains through the quality control practices by monitoring the recording of moisture, fire and temperature and send timely alert to concern officials. It can also capture fire, earthquake and can alert the respective nearest authority like Fire Station, Hospital, and Police besides alerting CWC officials for mitigation. CWC is operating 432 Warehouses across the country with a storage capacity of 9.96 million tones providing warehousing services for a wide range of products ranging from agricultural produce to sophisticated industrial products. Warehousing activities of CWC include food grain warehouses, industrial warehousing, custom bonded warehouses, container freight stations, inland clearance depots and air cargo complexes. India has a very high frequency of great earthquakes (magnitude greater than 8.0). For instance, during 1897 to 1950, the country was hit by four great earthquakes. However, the frequency of moderate earthquakes (magnitude 6.0 to 7.0) in the country is rather low. Among all these risks, we are going to develop a prototype to avoid these by using the Arduino based IoT technology.

Keywords: *Internet of Things (IoT), Arduino kit, temperature sensor, fire sensor, moisture sensor, earthquake sensor.*

I. INTRODUCTION

Arduino is an open source computer hardware and software company, project, and user community that designs and manufactures single-board microcontrollers and microcontroller kits for building digital devices and interactive objects that can sense and control objects in the physical world. Arduino board designs use a variety of microprocessors and controllers.

The boards are equipped with sets of digital and analog input/output (I/O) pins that may be interfaced to various expansion boards (shields) and other circuits. The boards feature serial communications interfaces, including Universal Serial Bus (USB) on some models, which are also used for loading programs from personal computers. The microcontrollers are typically programmed using a dialect of features from the programming languages C and C++. In addition to using traditional compiler tool chains, the Arduino project provides an integrated development environment (IDE) based on the Processing language project.

The **Internet of things (IoT)** is the network of physical devices, vehicles, home appliances and other items embedded with electronics, software, sensors, actuators, and network connectivity which enables these objects to connect and exchange data. Each thing is uniquely identifiable through its embedded computing system but is able to inter-operate within the existing Internet infrastructure.

II. LITERATURE SURVEY

1. Detecting Soil Moisture Using Microcontroller

Suitable soil water amount is an obligatory condition for ideal plant growth. Also, water being a crucial element for life nourishment, there is the prerequisite to circumvent its excessive use. Irrigation is a supreme consumer of water. This calls for the need to control water supply for irrigation purposes. Pasture should neither be over-irrigated nor under-irrigated. Soil Monitoring is one tool to provide soil information. In this project we use the information obtained from the input sensors which is handled using the neural networks algorithm and correction factors for monitoring. Soil monitoring, providing a series of assessments showing how soil conditions and/or properties change over time. The use of simple obtainable components decreases the manufacturing and maintenance costs. This makes this system more economical, appropriate and a low maintenance solution for applications, mainly in rural areas and for small scale agriculturists.

2. smart micro grid using Multi Agent System (MAS) environment

This paper aims to establish a micro controller and IOT based Multi Agent System (MAS) for progressive demand side response of a solar micro-grid. High penetration of renewable energy resources needs new coordination and control approaches to meet the stochastic nature of the environment and dynamic loadings this work basically presents an approach that makes it possible to integrate IoT devices to a MAS environment, for an upsurge in the level of integration and interoperability of a smart micro grid.

III. PROPOSAL METHOD

For the early warning system, we are using the technology of IoT with Arduino kit. Low cost IT solution preferably around Internet of the things (IoT) sensor and IoT data integration to existing application software.

Arduino is an open source computer hardware and software, manufactures single-board microcontrollers and microcontroller kits for building digital devices and interactive objects that can sense and control objects in the physical world. It's aiming to provide a low-cost and easy way for novices and professionals to create devices that interact with their environment using sensors and actuators. Here, we are using the sensors which are used to sense the moisture, temperature, fire and earthquake.

1. Moisture sensor:

Soil moisture sensors measure the volumetric water content in soil. Since the direct gravimetric measurement of free soil moisture requires removing, drying, and weighting of a sample, soil moisture sensors measure the volumetric water content indirectly by using some other property of the soil, such as electrical resistance,

dielectric constant, or interaction with neutrons, as a proxy for the moisture content. The relation between the measured property and soil moisture must be calibrated and may vary depending on environmental factors such as soil type, temperature, or electric conductivity. Reflected microwave radiation is affected by the soil moisture and is used for remote sensing in hydrology and agriculture. Portable probe instruments can be used by farmers or gardeners. Soil moisture sensors typically refer to sensors that estimate volumetric water content. Another class of sensors measure another property of moisture in soils called water potential; these sensors are usually referred to as soil water potential sensors and include tensiometers and gypsum blocks.

2. Temperature sensor:

A temperature sensor is a device, typically, a thermocouple or RTD that provides for temperature measurement through an electrical signal. A thermocouple (T/C) is made from two dissimilar metals that generate electrical voltage in direct proportion to changes in temperature. Temperature Sensors measure the amount of heat energy or even coldness that is generated by an object or system, allowing us to “sense” or detect any physical change to that temperature producing either an analogue or digital output. There are many different types of Temperature Sensor available and all have different characteristics depending upon their actual application. A temperature sensor consists of two basic physical types: Contact Temperature Sensor Types – These types of temperature sensor are required to be in physical contact with the object being sensed and use conduction to monitor changes in temperature. They can be used to detect solids, liquids or gases over a wide range of temperatures. Non-contact Temperature Sensor Types – These types of temperature sensor use convection and radiation to monitor changes in temperature. They can be used to detect liquids and gases that emit radiant energy as heat rises and cold settles to the bottom in convection currents or detect the radiant energy being transmitted from an object in the form of infra-red radiation (the sun).

3. Block diagram

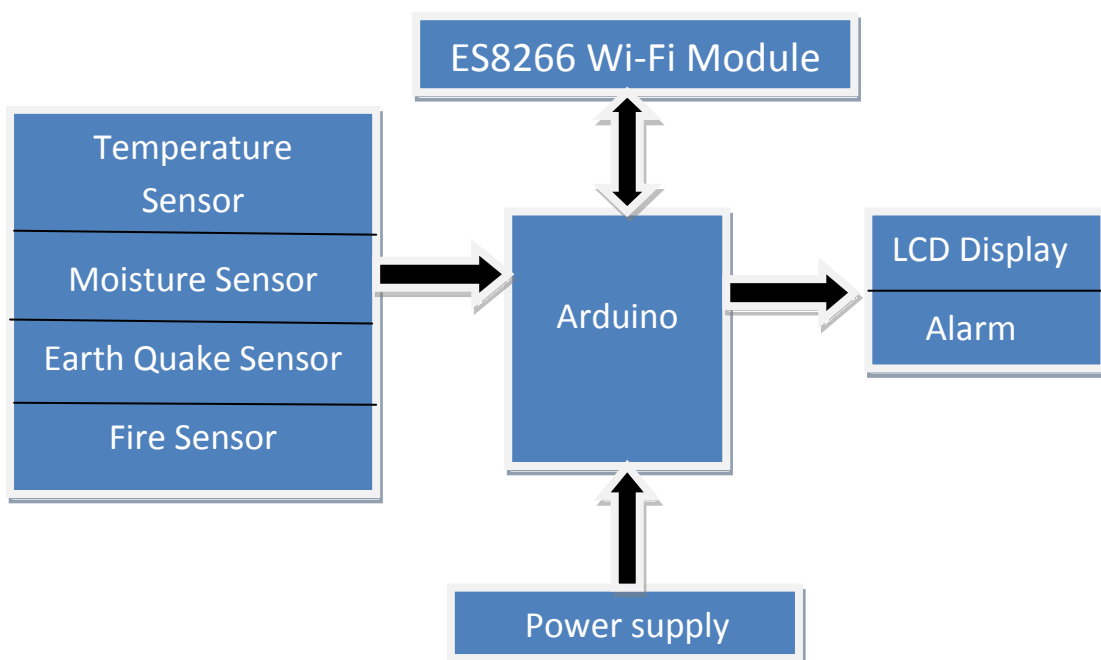

4. Fire Sensor:

A **flame detector** is a sensor designed to detect and respond to the presence of a flame or fire, allowing **flame detection**. Responses to a detected flame depend on the installation, but can include sounding an alarm, deactivating a fuel line (such as a propane or a natural gas line), and activating a fire suppression system. When used in applications such as industrial furnaces, their role is to provide confirmation that the furnace is properly lit; in these cases they take no direct action beyond notifying the operator or control system. A flame detector can often respond faster and more accurately than a smoke or heat detector due to the mechanisms it uses to detect the flame.

5. Intelligent Earthquake Sensor SES70



The SES70 Intelligent Earthquake Sensor detects the acceleration caused by an earthquake using a small built-in accelerometer and then calculates and outputs the synthetic acceleration, the estimated Japan Meteorological Agency seismic intensity scale (shindo scale) value, and the SI value, which is an estimation of damage to structures caused by earthquake motion.

IV. CONCLUSION

For the development of an early warning system to control the storage loss of food grains through the quality control practices by monitoring the recording of moisture, fire and temperature and send timely alert to concern officials. It can also capture fire, earthquake and can alert the respective nearest authority like Fire Station, Hospital, and Police besides alerting CWC officials for mitigation. Among all these risks, we are going to develop a prototype to avoid these by using the Arduino based IoT technology.

REFERENCES

- [1.] Brown, Eric. "Who Needs the Internet of Things?". Linux.com. Retrieved 23 October 2016 (13 September 2016).
- [2.] Brown, Eric. "21 Open Source Projects for IoT". Linux.com. Retrieved 23 October 2016 (20 September 2016).
- [3.] "Internet of Things: Science Fiction or Business Fact?" (PDF). Harvard Business Review. November 2014. Retrieved 23 October 2016.

- [4.] Justin Lahart (27 November 2009). "Taking an Open-Source Approach to Hardware".The Wall Street Journal. Retrieved 2014-09-07.
- [5.] Hernando Barragán (2016-01-01). "The Untold History of Arduino".arduinohistory.github.io. Retrieved 2016-03-06.
- [6.] AD590 | datasheet and product info 2-Terminal IC Temperature Transducer | Analog Devices". www.analog.com. Retrieved 2015-11-23.
- [7.] AD592 | datasheet and product info Current Output – Precision IC Temperature Transducer | Analog Devices". www.analog.com. Retrieved 2015-11-23.
- [8.] <http://www.iothandbook.org/>