

Interference Reduction in Wireless Communication using Adaptive Beam forming Algorithm and Windows

V.SANDEEP KUMAR¹, P.ASHOK KUMAR²

1,2 Research Scholar, Dept of ECE, Sri Satya Sai University of

Technology & Medical Sciences, Sehore, MP, (India)

ABSTRACT

A novel based approach of Adaptive beam forming algorithm is proposed for the interference reduction in wireless communication application based on Minimum Bit Error Rate(MBER).By means of LMS Algorithm we can switch and steer the antenna beam electronically and with use of Windowing techniques, Block data and sample by sample adaptive implementation of MBER's solution is developed. HPBW of antenna is enhanced by making use of windowing techniques like Rectangular, Hamming, Kaiser, Chebyshev windows. In CDMA, the system gain will improve the performance of the system, where the no of interferences in quite large and helps to increase the spectral efficiency of wireless communication system. Any beam former that can depress large number of interferers (by improving the system capacity and performance).Such beam former is referred as "smart antenna". Signal to Interference Ratio (SIR) of system is efficiently improved by forming narrow beam towards the desired user by suppressing the unwanted side lobes.

Keywords: Interference, window, LMS, HPBW, Array, Algorithm, Smart Antenna, Beam forming.

1.INTRODUCTION

Wireless system performance offers a broad range of ways to improve smart antennas. Wireless communication is used in wide areas of applications

[1]The first wireless Communication is referred to the work done by Marconi, by transmitting the Morse signal across the Atlantic Ocean in 1901.The Advanced Mobile Phone System (AMPS) has been developed in Bell lab i.e., 1G(First Generation Level).Because of high user demand of spectrum to automatically more number of users. At that time, they introduced frequency re-use concept(same frequency is used in different cells). This can be achieved by dividing the total area of coverage into the hexagonal cell(it is area covered by base-station)

[2]By adopting these hexagonal cells the overlapping problem is removed and it represents good approximation of cellular cells. This process is done by splitting the radio resources into groups.

[3]The groups assigned to different contiguous cells. This pattern is repeated, as often as necessary, until the entire area is covered.

II. MOBILE COMMUNICATION EVOLUTION

Prime factors of wireless mobile communication were to obtain qualitative service and capability. For this reason, we developed eventually the four techniques as given below [1].

1. FDMA
2. TDMA
3. CDMA
4. SDMA

In FDMA, the whole bandwidth is divided into number of non- overlapping channels (frequency bands).In TDMA, the whole bandwidth is allotted to different user according to time of non-overlapping slot allotted to user. Here time is divided instead of frequency as compared to FDMA. In CDMA, Signals from different users transformed simultaneously and are separated by a unique orthogonal PN-sequence code to each user (to avoid interference). In SDMA, *“it allows the use of same radio resonances at time, frequency with same code that allocates physical location, which is separately separated in terms of distance and angle”*[2].

As numbers of subscribers are increasing rapidly, we go for 2G (second generation), it has some advantages compared to 1G i.e. compression & coding techniques linked with digital technology. Multiple accesses like TDMA&CDMA are used along with FDMA in 2G systems. But unable to meet the demands. So, in order to accommodate more Capacity & Bandwidth need, The WARC (World Administrative Radio Conference) develops 3G (Third Generation) for the extension of 2G. The proposal of 3G technology is referred as “International Mobile Telecommunication(IMT-2000)”. It uses well improved & sophisticated modulation schemes to enhance the spectrum allocation.

3G spectrum is being designed for high speed internet access, voice, videos, HQ images transmission, WCDMA techniques are used in 3G Technology. It is often called 3GPP(Third Generation Partnership Project). There are two modes in 3GPP i.e. FDD (Frequency Division Duplexing) & TDD (Time Division Duplexing) mode [3] & [6].

III. SMART ANTENNA TECHNOLOGY

Antenna Arrays are used to radiate power into free space. To shift the antenna beam to various positions, we can adjust the relative amplitude and phase of antennas elements. This process is called scanning (or) steering[4].

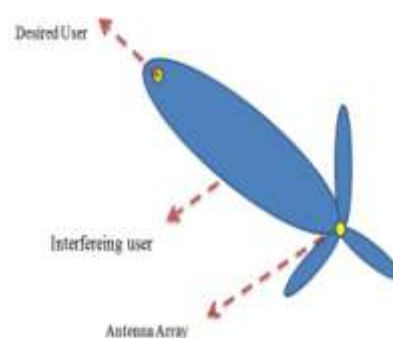

Fig. 3.1 Radiation of Smart Antenna

By choosing proper antenna coefficient smart antennas can switch the beam electronically, it provide narrow beam toward the desired direction & low side beam towards undesired direction [4]. For this we adopted the smart antenna technology. The Model view about the working of smart antenna is shown in Fig 3.1; there is narrow beam in the direction of desired user [7].

The functioning of smart antenna is divided into two cases

1. DOA (Direction of Arrival) Estimation
2. Beam forming

DOA Estimation means identifying the strength and direction of signals by its arriving. Several techniques are used such as MUSIC (Multiple Signal Classification), ESPRIT, and Matrix pencil methods. Beam forming is a signal processing technique uses for signal transmission & reception.

This can be achieved by scanning the elements of arrays, where signal experience constructive interference in particular angle, whiles other experiences destructive interference.

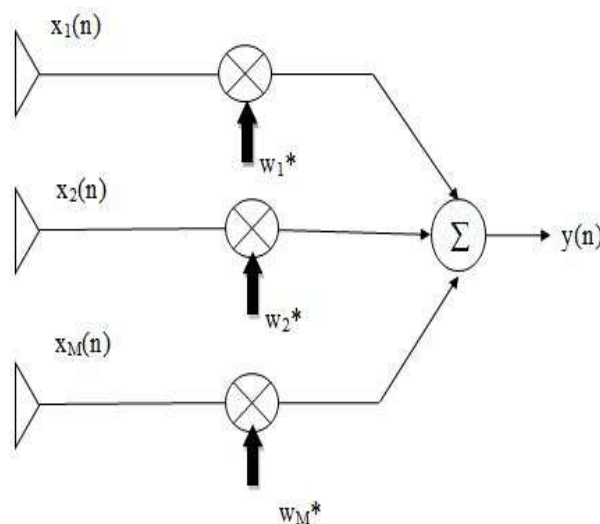

Fig. 3.2 Beam forming Operation

$$y(n) = \sum_{i=1}^M W_i^* X_i(n)$$

$$= W^H X(n) \quad \text{--- 3.1}$$

IV. LOW SIDE LEVEL ALGORITHM

A Simple adaptive technique for steering of antenna beam electronically is LMS (least mean square) algorithm. LMS Algorithm estimates the vector from available data. It incorporates iterative procedure that makes a successive correction to the weight vector i.e. in the direction of negative gradient vector which eventually leads to minimum MSE. It is the best among all other algorithm. The most sophisticated technology for smart antenna

technology is SDMA which is having most advanced signal processing technique for steering of an array. In SDMA (Space Division Multiple Access), more than one user is allocated to the same communication channel simultaneously in the same cell, separated by only angle.

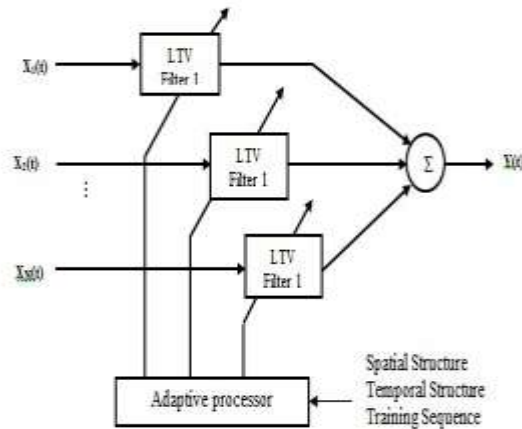

Fig.4.1 Typical Array Processing Architecture

The LMS algorithm can be summarized in following equations

Output equation is given by

$$y(n) = w^h x(n) \text{----- 4.1}$$

Error equation is given by

$$e(n) = d^*(n) - y(n) \text{----- 4.2}$$

Weight W in Output eq 4.1 is given by

$$w(n + 1) = w(n) + 2\mu x(n)e^*(n) \text{----- 4.3}$$

Where μ = step size parameter that controls the convergence of LMS algorithm.

V.METHODS FOR CONTROLLING SIDE LOBES

Given an array of M elements, the outputs of general beam former.

$$z[n] = \sum_{m=0}^{M-1} w_m[n]x_m[n - \Delta_m] \text{----- 5.1}$$

Where,

$x_m[n]$ = time sample “n” from element “m”.

$w_m[n]$ = weight applied to channel “m” at time “n”.

Δ_m = time delay applied to the output from channel 'm' in order to focus the beam.

In conventional, non-adaptive beam formers, those weights are pre-defined. Using uniform weights is one option, but a more common approach is to use window function such as Hamming and Kaiser to control the side lobe levels.

In my work, four windows i.e., Rectangular, Kaiser, Hamming, and Chebyshev and window functions are used. In signal processing, a window function (also known as apodization function or tapering function) is a mathematical function i.e., constant at certain interval and zero on other hand. This is obtained by applying signal and window multiplication. The signal which is at window is outcome and beside the two sides is zero i.e., viewing a signal through a window.

VI. SIMULATION

The result of low side lobe control techniques are demonstrated using MATLAB .In this Simulation.

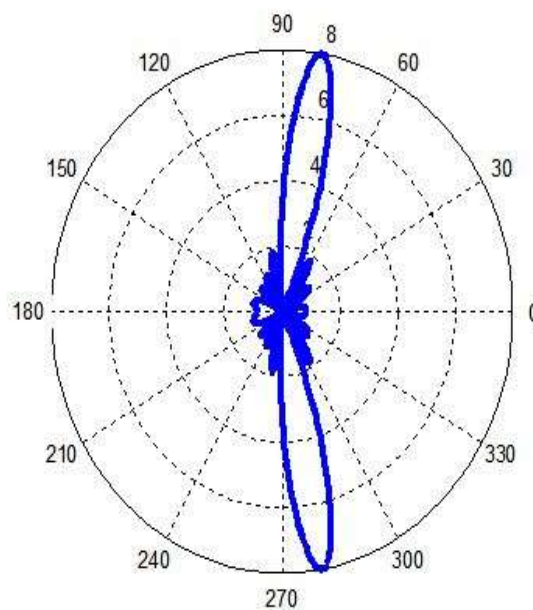

Fig.6.1 Desired Signal

We use an 8-element linear array with its individual element spaced at half wavelength distance. In this, we can show how interfering signals of the same frequency as the desired signal can be separated to achieve rejection of co-channel interference.

The antenna radiation pattern for an 8-element linear array is shown in figure. In this case the desired angle is arrived at 80° degrees and there are three interfering signals arriving at angles 10°, 40° and 60° respectively. The LMS algorithm is able to iteratively update the weights and achieve maximum in the direction of the desired signal.

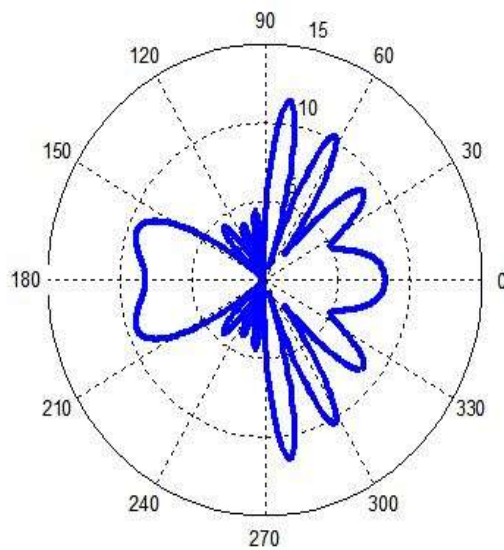

Fig.6.2 Desired and Interference Signal

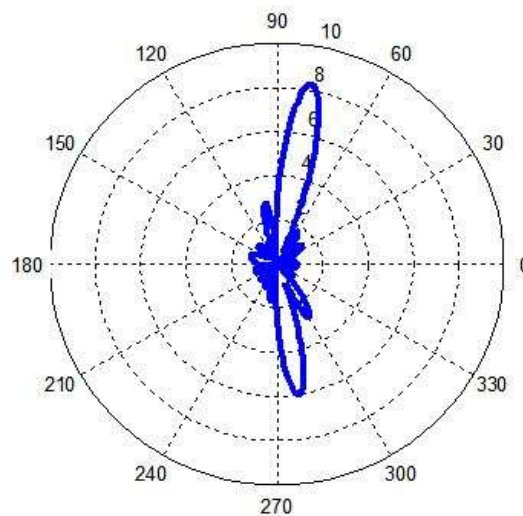

Fig.6.3 Signal Obtained with LMS Algorithm

VII.COMPARISIONOFERROR VALUESFOR DIFFERENT WINDOWS

The LMS algorithm tracks the desired signal. However, as the adaptation process continues, the weight converges towards its optimum and the weighted signal $y(t)$ follows the desired signal $s(t)$ more closely with a small error.

The error signal is given by

$$e[k] = d[k] - y[k] = d[k] - X_k^T W_k \text{-----7.1}$$

Where $d[k]$ is the desired signal, and $y[k]$ is the output of the beam former

Table 7.1 - Error Value for Different Windows

| S.No | Taper | Error |
|------|-------------|---------|
| 1 | Rectangular | -0.0058 |
| 2 | Hamming | -0.0005 |
| 3 | Chebyshev | 0.0037 |
| 4 | Kaiser | -0.003 |

Table 7.2 - 3- dB beam width for various Window functions

| S.No | Taper or Window | Half Power Beam width (in degrees) | Half Power Beam width (in degrees) |
|------|-----------------|------------------------------------|------------------------------------|
| | | M=4 | M=8 |
| 1 | Rectangular | 38.07 | 21.29 |
| 2 | Hamming | 50.76 | 28.38 |
| 3 | Chebyshev | 27 | 15.102 |
| 4 | Kaiser | 36.35 | 20.33 |

VIII. CONCLUSION

In a CDMA system all transmitted signals turn out to be disturbing factors to all other users in the system in the form of interference. Therefore the system capacity strongly depends on the interference level in the system. Hence, In the case of CDMA systems, it is proposed that smart antenna will control interference by forming main lobe towards desired user and low/depressed side lobe towards the undesired users or interferers. Hence narrow beam low side-lobe algorithms, which can taper array weights of any beam former with suitable taper function, are considered appropriate for CDMA systems. It is found that the role of window function is quite impressive and economical from the point of view of computational complexity and ease associated with its application in controlling side lobes. It is proposed from this study that Chebyshev window can be flexible to decrease the maximum side lobe level and achieves narrow beam towards desired user when compared to other adjustable and fixed side lobe yielding windows. Therefore using Chebyshev window, the gain of the system will be increased and it will definitely improve the performance of CDMA based wireless communication system, where the number of interferes is quite large.

REFERENCES

- [1.] Dongback SEO, "Evolution and standardization of Mobile Communication and Technology", Hanray University, Republic of Korea.
- [2.] T. L.Singal, "Wireless Communication", Tata McGraw Hill Edition.

- [3.] BorkoFurht, Ph.D, Mohammad Illiyas, Ph.D, “Wireless Internet Handbook Technology, Standards and Applications”
- [4.] T.K.Sarkar, MichaelC.Wicks, M.Salazarpalma, Robert J Bonneaus, “ Smart Antennas” Wiley.com.
- [5.] A.F. Naguib, “Adaptive antennas forDMA wireless networks,” Ph.D. dissertation, Stanford University, Aug. 1996.
- [6.] “Antenna Theory: Analysis and Design, 3rd Edition By Constantine A. Balanis.
- [7.] Gross, Frank.B(2005), “Smart Antennas for Wireless Communication with MATLAB”, McGraw Hill.
- [8.] “ 3GPP Third Generation Partnership Project, TS 25.102-105, version June2001.
- [9.] A. Narula, M. J. Lopez, M. D. Trott, and G. W. Wornell, “Efficient use of side information in multiple-antenna data transmission over fading channels,” *IEEE Journal on Sel. Areas in communications*, vol. 16, no. 8, pp. 1423–1435, Oct.1998.
- [10.] A. J. Paulraj and C. B. Papadias, “Space-time processing for wireless communications”, *IEEE Transaction on Vehicular Technology*, vol. 43, pp.691-697, Aug. 1994.
- [11.] A. J. Paulraj, RohitNabar and Dhananj Gore, “Introduction to Space time Wireless Communications”, Cambridge University Press, 2003.
- [12.] .B. D. Van Veen and K. M. Buckley, “Beamforming: A versatile approach to spatial filtering”, *IEEE ASSP Magazine*, pp. 4-24, April 1988.
- [13.] .C.Christodoulou and N.Herscovici “Smart Antennas in Wireless Communications: Base-Station Diversity and Handset Beamforming”, *IEEE Antennas and Propagation Magazine* Vol.3, no.5, pp.142-151, May 2000.