

TEMPERATURE CONTROLLED DC FAN

Dr.Sudha Senthilkumar¹, Dr. K. Brindha² , Prof.Rathi.R³

Siya Hardi⁴,Sadhika Kataria⁵

School of Information Technology and Engineering, VIT University, Vellore

ABSTRACT

This paper describes the working of an automatically temperature controlled DC fan. It uses the technology called IOT-Internet Of things. Basically in IOT the device takes the input from environment or outside world and works/gives output accordingly. The main objective of this paper is to device a temperature controlled fan using the analog components, also to measure the threshold temperature for which the fan works. An alarm circuit is also attached to indicate the fan turn on.This device can be used in smart homes.The temperature controlled dc fan is designed to turn off and turn on according to the temperature surroundings. This device majorly functioning on the behavior of the thermistor has a major advantage in power saving. The device will be designed in a way that the threshold temperature(the minimum temperature) to turn on the fan will be modified in accordance to the choice of the user.

Keywords: *IOT, Thermistor, DC Fan, Device, Temperature*

INTRODUCTION

Overall the general public does not want to manually change the fan speed with the change in temperature. The temperature controlled DC fan is meant to address this issue.It automatically switches on/off the fan as change in temperature is observed by sensors.It can be used or in smart homes, smart cities.It will also save the electricity and power consumption.

It is mentioned in many articles that billions of KW-hrs of energy per year is used by fans.And this constitutes of 15% of power consumption.

So our paper deals with this issue, i.e reducing the power consumption by automatically controlling the speed and power consumed on the basis of temperature.So microcontroller can be used to control the speed by measuring or evaluating the changes in temperature.

1.1 AT MEGA 8

Block Diagram:

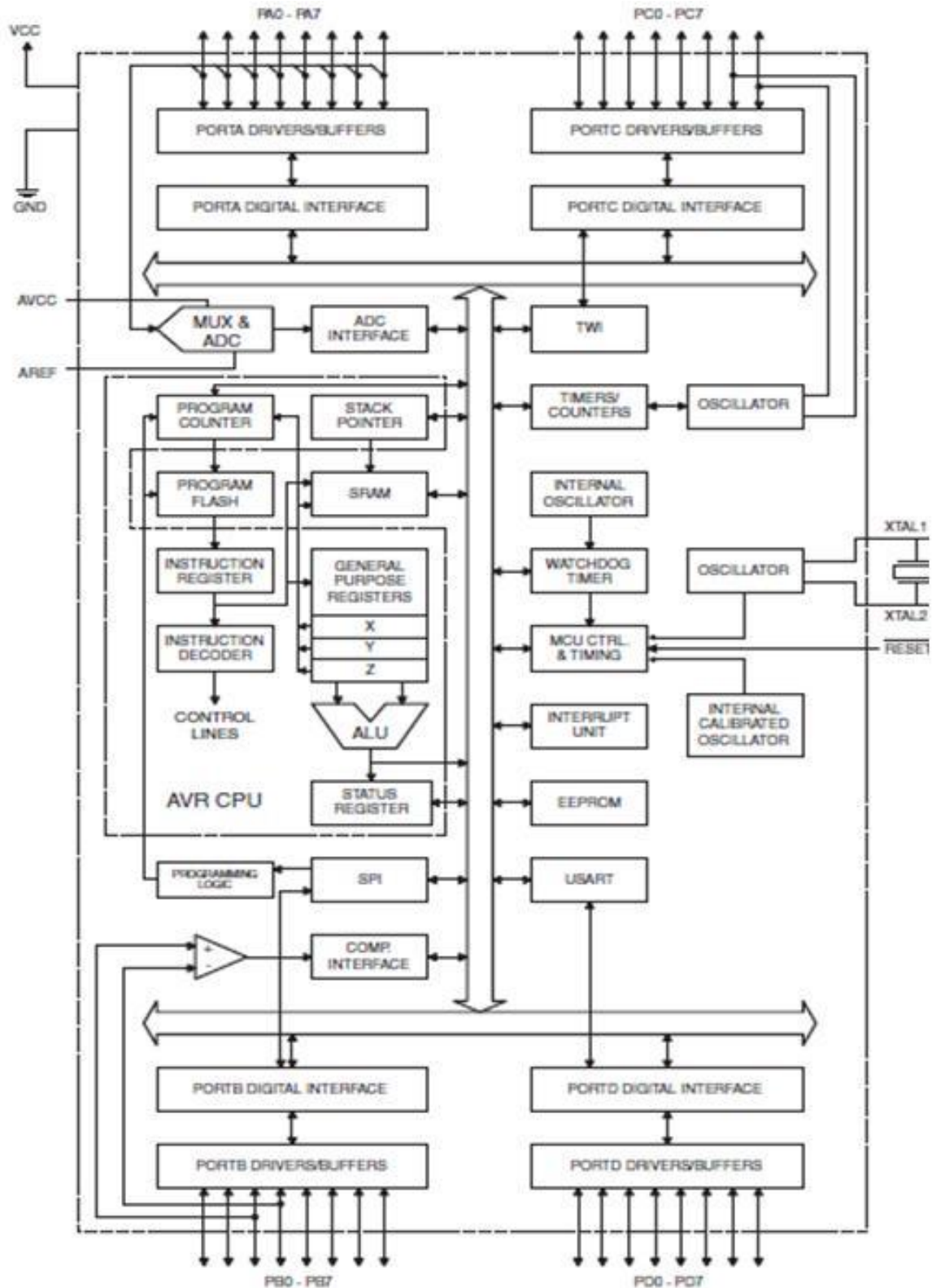



1.2 Pin Mapping

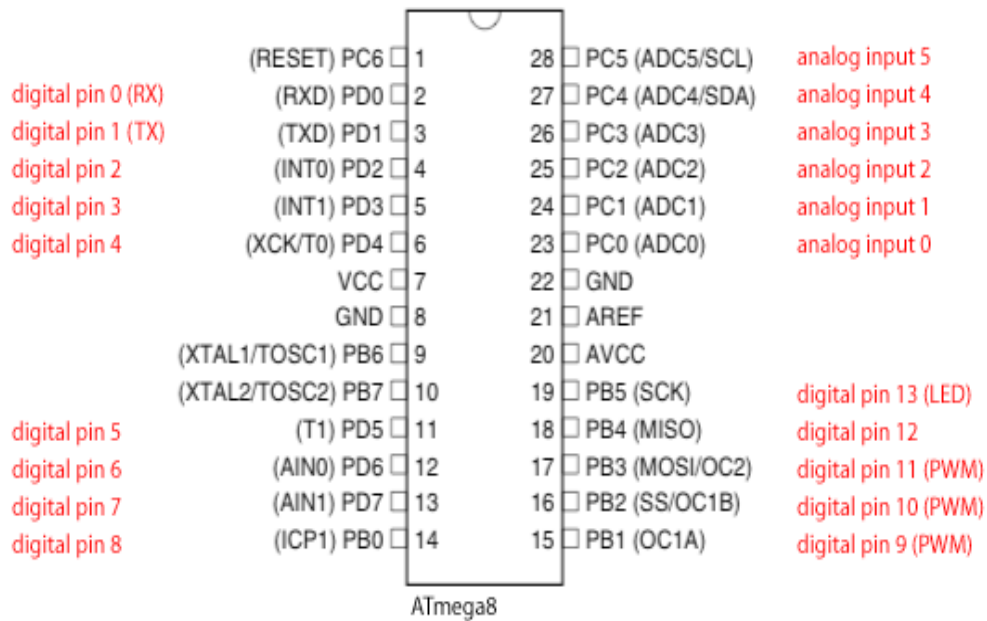

1.3 Specifications:

EEPROM	512 bytes
Flash Memory	8 Kilobytes
DC Current per Input/output Pin	40 milli Ampere
Static RAM	1 Kilo Byte
Digital Input/output Pins	14
Analog Input Pins	6



1.4 Pin Descriptions:

VCC	Voltage used for digital purpose
GND	Ground
Port B (PB7 to PB0) TOSC1/TOSC2/XTAL L1/XTAL	Port B is can be used as input or output. That's why it is called bidirectional input output port and pull up register for each bit is used. When the pull up register is activated Port B pins are kept as low. When reset condition is kept high Port B pins reached in tri state. In this situation clock pulse may or may not run. Inverting oscillator amplifier input comes from the PB6. PB7 is used as output of inverting oscillator amplifier.
Port C (PC5 to PC0)	Port C also can be used as an input and output port so it is also a bidirectional port like Port B. Pull up register is also used for each bit of Port C (PC0 to PC7)
PC6/RESET	PC6 bit is different from all other bits of Port C. This is used as input output pin when RSTDISBL fuse is programmed.
Port D (PD7 to PD0)	Port D is can be used as input or output. That's why it is called bidirectional input output port and pull up register for each bit is used. When the pull up
Reset data.	Reset is used to reset the values of all the Ports, Registers and Interrupts of the microcontroller.

II. ALGORITHM

- Preparing the main analog network for the temperature sensitive control
- Attaching the alarm circuit.
- Attaching the temperature measuring circuit.
- Programming the arduino pins according to the function required.
- Providing the voltage control to the circuit components.
- Checking the output using the blow drier to increase the temperature

III. SYSTEM DESIGN

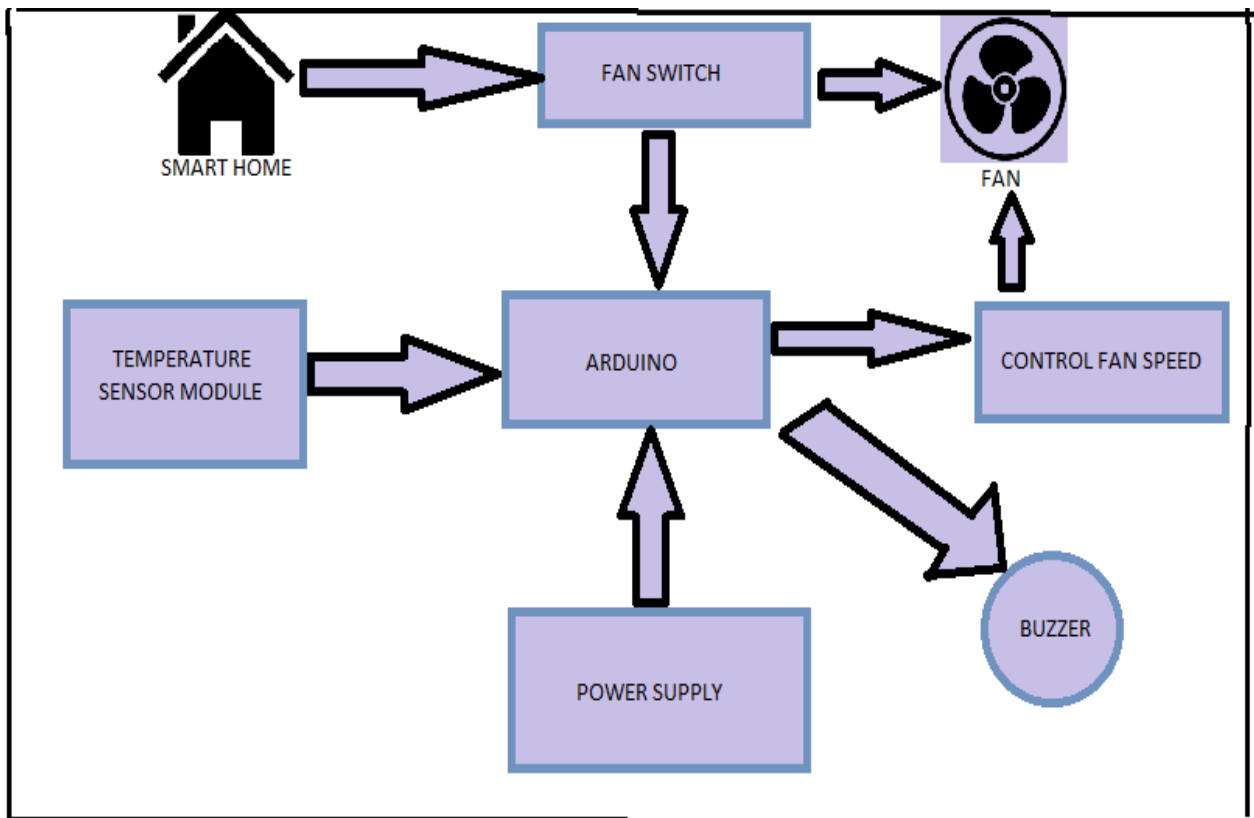

3.1 Hardware Design

3.1.1 Architecture of control module

An Arduino [11] is an open source computer hardware and software, project and user community that designs and manufactures Microcontroller-based tools for building digital devices and interactive objects that can sense and control the real world. The AVR is a Modified Harvard architecture[12].It is a 8-bit RISC based single chip microcontroller which was developed by Atmel.The AVR (Alf (Egil Bogen) and Vegard (Wollan)'s RISC processor) was one of the first microcontroller families to use on chip flash memory (32KB) for program storage.AVR microcontrollers handle 16-bit applications With a single cycle instruction.ATmega is low power, high performance device.

3.1.2 Sensor module

Temperature sensors measure the temperature of the surrounding .It measures the temperature variations.It gives the values in in centigrade(Celsius). It has goot accuracy (about 0.5 degree Celsius) .The relation between the measured property and temperature must be calibrated.This changes in temperature determines the speed of fan and whether to turn off or turn on the fan.

3.1.3 Fan module

Temperature sensors measure the temperature of the surrounding .It measures the temperature variations.As temperature value reaches some threshold value it switches on this DC fan.This is a simple fan operated by direct current.

III. EXPERIMENTAL SETUP

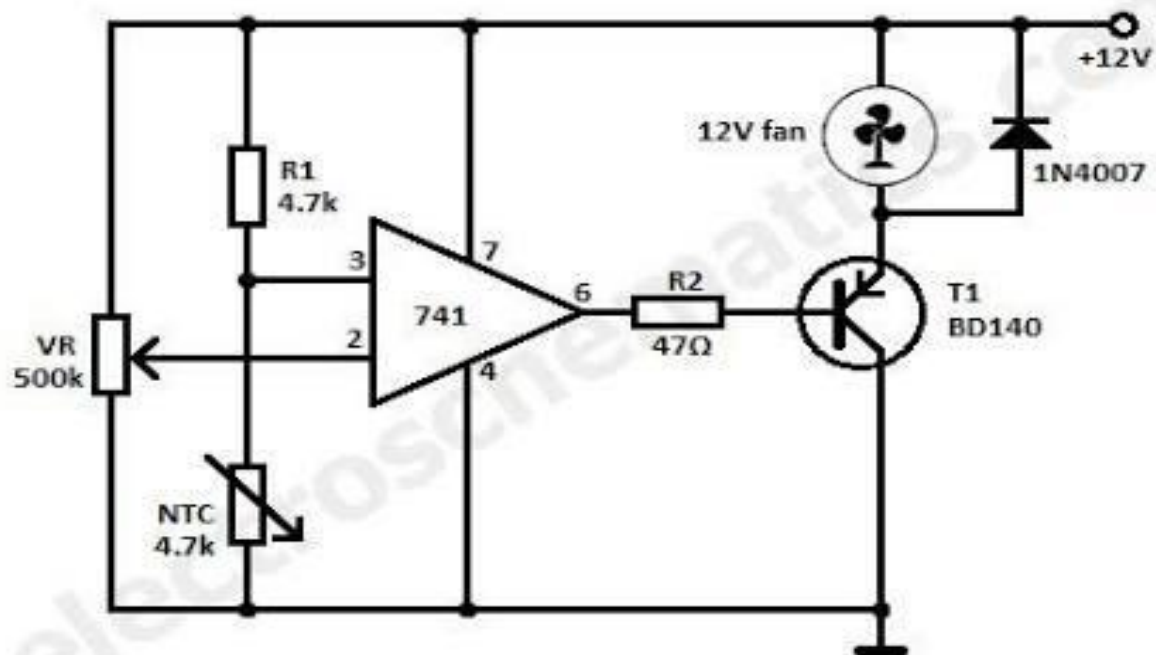

Thermistor is used in the dc fan which is controlled by temperature and this is it's working principle. The component whose resistance changes with temperature is a thermistor. The negative temperature coefficient (NTC) and the positive temperature coefficient (PTC) are the two major classifications of a thermistor. But we have used a NTC type thermistor. Negative temperature coefficient has an inverse relation between the resistance and the temperature. Whereas, in positive temperature coefficient there is a direct relation between resistance and temperature.

The NTC thermistors are made up of metal oxides. The oxides of iron, copper, titanium, nickel, manganese are widely used. A wide range of temperature coefficient characteristics as well as resistivity is made available just by a change in the oxide type or the sintering temperature or atmosphere.

The potentiometer is working as the voltage regulator and hence it also defines the threshold temperature for the fan, i.e. by varying the resistance of the potentiometer we can alter the current that flows through the circuit at any given time. Hence, the voltage across thermistor changes so the threshold temperature at which thermistor starts conducting changes and hence the on the temperature of the fan changes.

The voltage comparator that is used as Op amp IC741 and voltage between the two inputs(inverting and non-

inverting terminals) is contrasted. The voltage divider circuit is created by putting non-inverting terminal, i.e., pin number 3 between R1 and thermistor. The Potentiometer is made to connect to an inverting terminal, i.e., pin number 2. As a result, the fan speed is regulated by the op amp output. There is more voltage across pin number 3 caused by voltage divider circuit when there is a decrease in resistance. This decrease in resistance results from the increase in the surrounding temperature, which in turn causes the thermistor temperature to increase as well.

Now we can say that fan speed increases with the output voltage. For the temperature measuring device the Arduino circuit and program-

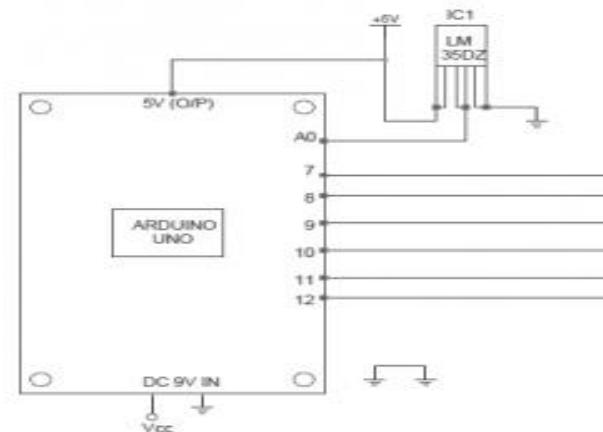

```
int value=0; //initializing variables
float volts=0.0;
float temp=0.0;
void setup()
{
  pinMode(A0,INPUT); //setting arduino pin3 as input
  Serial.begin(9600);
}
void loop()
{
  value=analogRead(A0); //read from A0
  volts=(value/1024.0)*5.0; //conversion to volts
  temp= volts*100.0; //conversion to temp Celsius
  Serial.print("temperature= ");
  Serial.println(temp);
  delay(500);
}
```

IV. CONCLUSIONS AND FUTURE WORK

The circuit according to the design was build and the output was verified. The temperature of the circuit was increased using a blow drier and then the fan starts at the threshold temperature that was set by the potentiometer. As the blow drier was turned off the temperature of the circuit drops and the fan slows down and finally turns off. The temperature measuring device reads the temperature of the surroundings. The alarm system indicates as the fan turns on.

- The threshold temperature of the fan can be changed by turning the potentiometer.
- The fan can be set to always power on mode by reducing the resistance of the potentiometer
- The circuit can also be implemented for AC voltage by making changes in the temperature control circuit.
- We can screen more parameters like humidity,light and in the meantime control them.We can send this information to a remote area utilizing versatile or web.
- We can draw diagrams of varieties in these parameters utilizing a PC.
- At the point when the temperature surpasses the farthest point, a call will be dialed to the individual given number by a programmed Dialer framework.

REFERENCES

- [1] Surabhi1 ,Upendra Prasad2 , Vivek Kumar Jain “Design and Fabrication of Temperature based DC Fan Speed Control System using Microcontroller and Pulse Width Modulation Technique” IJRSET 2015.
- [2] Ghana Shyam Soren, Ram Ashish Gupta,“ Temperature Controlled DC Fan using Microcontroller ”, National Institute of Technology Rourkela
- [3] Mustafa Saad, Hossam Abdoalgader, and Muammer Mohamed ,“Automatic Fan Speed Control System Using Microcontroller ”, 6th Int'l Conference on Electrical, Electronics & Civil Engineering (ICEECE'2014) Nov. 27-28, 2014 Cape Town (South Africa)
- [4] Maarten F. van Gelder,“A Thermistor Based Method for Measurement of Thermal Conductivity and Thermal Diffusivity of Moist Food Materials at High Temperatures ”,Virginia Polytechnic Institute and State University
- [5] Tabish,“A Operational Amplifier - IC 741 ”,Jamia-Physics
- [6] Avinash Kumar Shudhanshu, Raj Kumar, Sadashiv Raj Bharadwaj, Gaurav Singh, Amit Garg,“Technology based Laboratory to Improve Science Learning ”,Acharya Narendra Dev College, University of Delhi
- [7] Hongtai Cheng, Lina Hao, Zhong Luo, and Fei Wang,“Establishing the Connection between Control Theory Education and Application: An Arduino Based Rapid Control Prototyping Approach ”,IEEE papers,2016
- [8] Michael Riordan, Lillian Hoddeson, Connevers Herring,“The Invention of Transistors”,IEEE papers,2016
- [9] Anurag Singh Rajpoot ,Namrata Gadani , Sagar Kalathia,“Development of Arduino Based Quadcopter”,International Advanced Research Journal in Science, Engineering and Technology(IARJSET)
- [10] J.Shewchun,M.A Green,F.D King“Minority carrier MIS tunnel diodes and their application to electron- and photo-voltaic energy conversion—II. Experiment”,International Advanced Research Journal in Science, Engineering and Technology(IARJSET)
- [11] Rashid Hussain, JL Sahgal, Anshulgangwar, Md.Riyaj , “Control of Irrigation Automatically By Using

Wireless Sensor Network”, International Journal of Soft Computing and Engineering (IJSCE) ISSN: 2231-2307, Volume-3, Issue-1, March 2013

[12] Shaohua Wan, “Research on the Model for Crop Water Requirements in Wireless Sensor Networks”, 2012 International Conference on Management of e-Commerce and e-Government