

# A SECURE BIOMETRICS-BASED MULTI-SERVER AUTHENTICATION PROTOCOL USING RFID AND FINGER PRINT MODULE

Madireddy Rahul Rao<sup>1</sup>, M.Saritha<sup>2</sup>, H.Raghupathi (HOD)<sup>3</sup>

<sup>1</sup>Pursuing M.Tech(ES), <sup>2</sup>Assistant Professor, Assistant Professor<sup>3</sup>

<sup>1,2,3</sup> Visvesvaraya College of Engineering and Technology, Patelguda, Ibrahimpatnam,  
Rangareddy Dist. Telangana, (India)

## ABSTRACT

Recently, He and Wang proposed a robust and efficient multi-server authentication scheme the use of biometrics-based totally smart card and elliptic curve cryptography (ECC). In this paper, we first examine He–Wang’s scheme and show that their scheme is at risk of a acknowledged consultation specific transient statistics assault and impersonation attack. In addition, we show that their scheme does now not offer strong user’s anonymity. Furthermore, He–Wang’s scheme cannot offer the consumer revocation facility whilst the clever card is lost/stolen or user’s authentication parameter is found out. Apart from those, He–Wang’s scheme has a few layout flaws, together with wrong password login and its results, and wrong password update throughout password exchange segment. We then suggest a new at ease multi-server authentication protocol the use of biometric-primarily based smart card and ECC with extra safety functionalities. Using the Burrows–Abadi–Needham logic, we display that our scheme gives at ease authentication. In addition, we simulate our scheme for the formal security verification the use of the broadly established and used automated validation of Internet safety protocols and programs device, and show that our scheme is relaxed against passive and active assaults. Our scheme provides excessive protection together with low conversation price, computational fee, and sort of protection functions. As a result, our scheme is very suitable for battery-constrained cellular devices in comparison with He–Wang’s scheme.

**Keywords:- Lpc2148, RFID card & reader, fingerprint module, dc motor,l293d driver**

## I. INTRODUCTION

Security is the main aim of this project so instead of using controller we have plan to use ARM 7 processor architecture.so the processor used in this project is the 32 bit ARM processor with fingerprint and RFID modulecards with its card reader module and also a security locker system application . The following project is a small prototype to the complete considers idea. Thus only the important parameters for security based RFID and biometric based on the locker open and close. The modules used in the project is for aboutowner’s security.

## II. EXSISTING SYSTEM

Security plays major role in everywhere. In every sector biometric security gives more security than other security. All existing systems are level one securities like password, pattern lock etc. and other technology. Locker security is available with keys where anyone can access it those who had the keys. By this we can say that it has less security. This is the main drawback of the project.

## III. PROPOSED SYSTEM

In proposed we will provide two steps on securities. In first step user has to use RFID card and in next step user has to use Biometric. In the proposed system lpc2148 controller is used. We tend to simulate our theme for the formal security verification mistreatment the wide accepted and used machine-controlled applications and show that our theme is secure against passive and active attacks. Our theme provides high security beside low communication value, process value, and sort of security measures. As a result, the user can have very high security locker system. By this proposed system the user only can access the locker and no one can access it without his permission.

### Block Diagram

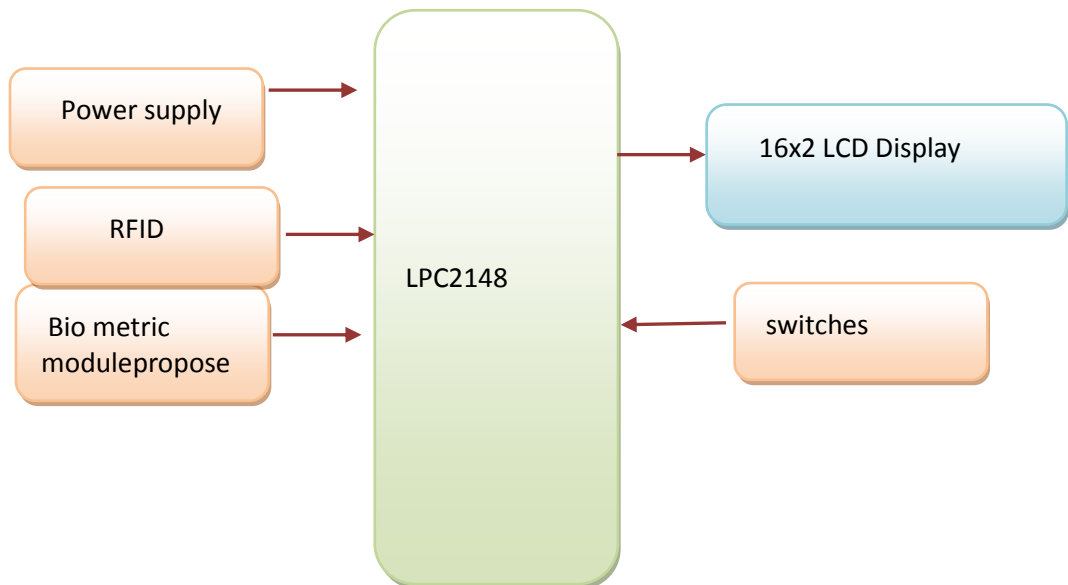

Fig 1: block diagram

### About Lpc2148 Microprocessor:

The LPC2148 microprocessor belongs to ARM 7 family. The LPC2148 board is a 32 bit ARM7TDMI-microprocessor with real-time emulation. It consist of 8 kilobyte to 40 kilobyte of on chip static RAM and 32kb to 512kB of on chip flash memory, the microprocessor works with 12 MHz crystal frequency The processor also support different protocols suite such as ISP (In System Programming),10 bit ADC affords variable analogue output

, 32-bit timers with external event counter (with 4 capture and match channels ).The processor also has RTC inbuilt thus extra hardware for the timer is not required.lpc2148 has 2 serial terminals which is called as UART0 and UART1.The same controller also has SPI and I2C

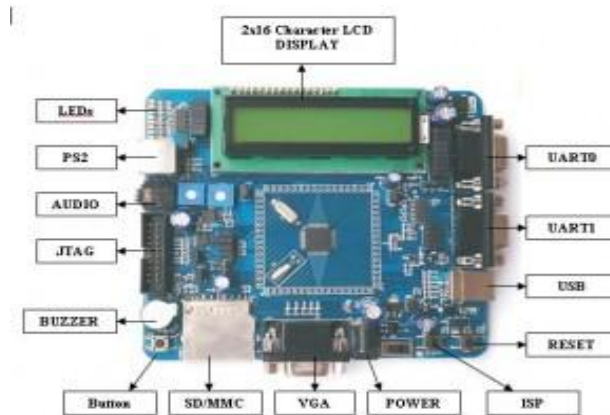

Fig 2 ARM7 LPC 2148 Development Board

### RFID Card & Reader Modules:

MFRC522 is used to 13.56MHz touch less communication with highly integrated chip card reader, the advance card reader module uses high frequency modulation and demodulation concept which is integrated in all 13.56MHz contact- less communication methods and protocols. The digital part of the high tech module handles ISO14443A framing and error detection technique. The module also support 14443A compatible transponder signal. The same module also support CRYPTO1 encryption algorithm and terminology validation .the two way data transfer is also possible by using the same module with a transfer rate of 424 kbit/s. Other modules are also available with slightly different differences and have advance.



Fig 3. RFID card &reader module

## **Fingerprint**

The ARA-EM01 is excessive performance fingerprint module advanced by way of Aratek statistics Technology Co, Ltd .It has several alternatives : easy reconstitute, powerful capabilities, compatible with PC, and more than one-features in a single module: Fingerprint enrolment, image technique, characters acquisition, fingerprint template advent, fingerprint template garage, fingerprint examine (1: one, 1: N), fingerprint delete. This module will paintings with completely different gadgets supported UAWRT like pc, SCM so on. Entirely simple circuits and fingerprint module will decorate your product into fingerprint authentication electricity. It is huge hired by means of herbal philosophy business, statistics security, get right of entry to management, identity authentication and opportunity protection enterprise



**Fig 4: finger print module**

## **L293D:**

The l293d are using high-current gain and half-H drivers. The l293d is designed to bidirectional drive currents of up to 1A at voltage from 4.5vto 36v.both devices are designed to drive inductive loads such as relays. its connecting dc bipolar stepping motors as well as other high current/voltage loads in positive-supply application.

## **IV. SOFTWARE DESIGN**

In this proposed project, we are using LPC2148 microprocessor and need to use the following software equipment to program for it.

1. Keil uVision 5.
- 2 Flash Programmer.

The Keil microVision is an IDE Embedded c Programming Language. In this IDE, we need to import all the utilities and libraries according of the controller. This IDE is very less difficult and is user friendly way to apply. It consists of all the C/C++ compilers, assemblers and debuggers in it. Here we need to generate a hex file to run the processor. The hex file consists of only binary numbers which is dumped in to the microprocessor. The flash magic is the programming software. The C/C++ software is written in IDE may be processed into Hex documented i.e. Hex file. By using the same hex file into the microcontroller and perform the task with application

## **V. WORKING DESCRIPTION**

The assignment operating description is as follows. The RF CARD is given most effective to the legal folks every time he/she deliver the card close to by the cardboard reader the cardboard get study with the serial number one,2,three,4. Security is the aim of this assignment so rather than the usage of controller we've got plan to use processor .So the processor used on this mission is the 32 bit ARM processor with fingerprint and RFID card with its card reader module and also a safety domestic software. The following undertaking is a small prototype to the entire considers idea. Thus best the important parameters for protection based RFID and biometric based totally on the door open and near. These module used in the assignment is residence proprietor in case of security we will offer two steps on securities. In first step person has to use Biometric and in subsequent step user has to apply RFID card. In the proposed system lpc2148 controller is used to which the DC motor are connected to the GPIO PINS.

## **VI. RESULT**

The following project is a small prototype to the complete considers idea. Thus only the important parameters for security based RFID and biometric based on the door open and close. These module used in the project is house owner in case of security its connecting hardware

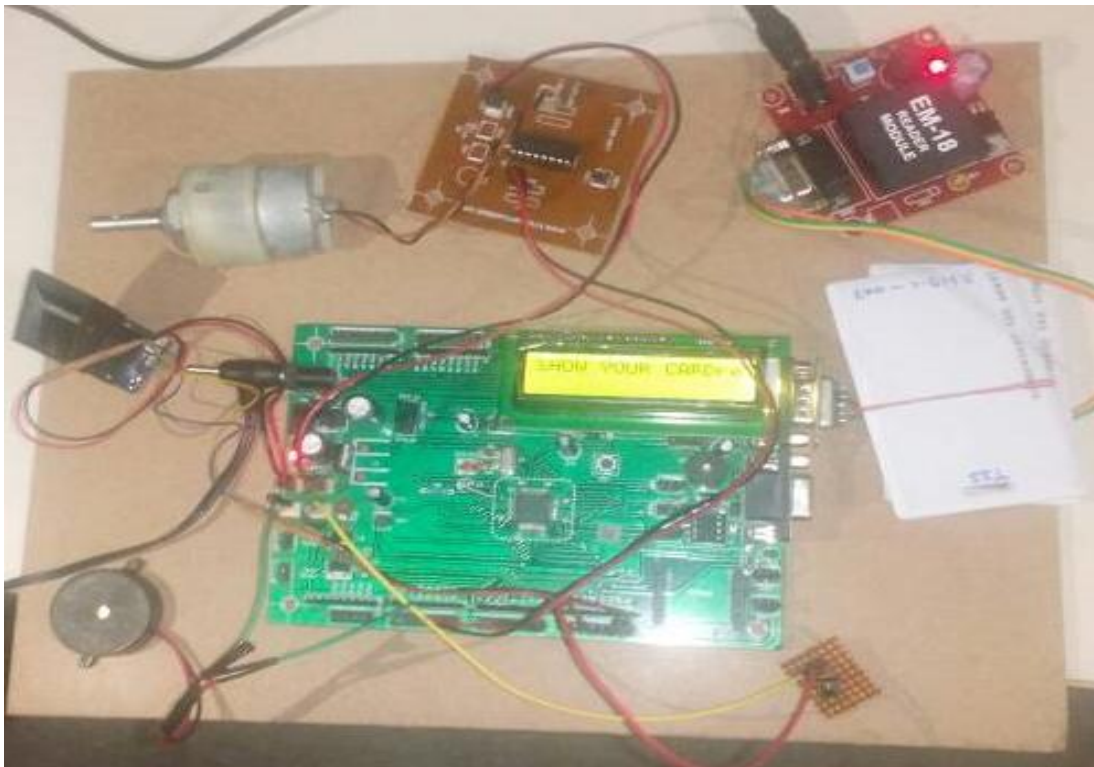

## **VII. CONCLUSION**

These end of the mission to simulate our subject matter for the formal protection verification mistreatment the wide typical and used gadget-managed validation of net protection protocols and applications device, and display that our theme is relaxed towards passive and energetic assaults. Our topic gives excessive protection beside low verbal exchange price, method cost, and kind of security



## **REFERENCES**

- [1]. Parvathy A, Venkata Rohit Raj, Venumadhav, Manikanta, “RFID Based Exam Hall Maintenance System”, IJCA Special Issue on “Artificial Intelligence Techniques - Novel Approaches & Practical Applications” AIT, 2011
- [2]. Gyanendra K Verma, Pawan Tripathi, “A Digital Security System with Door Lock System Using RFID Technology”, International Journal of Computer Applications (IJCA) (0975 – 8887), Volume 5– No.11, August 2010
- [3]. Kumar Chaturvedula .U.P, “RFID Based Embedded System for Vehicle Tracking and Prevention of Road Accidents”, International Journal of Engineering Research & Technology (IJERT) , Vol. 1 Issue 6, August – 2012, ISSN: 2278-0181
- [4]. Islam, N.S. Wasi-ur-Rahman, M. “An intelligent SMSbased remote Water Metering System”. 12th International Conference on Computers and Information Technology, 2009, 21-23 Dec. 2009, Dhaka, Bangladesh.
- [5]. Mohd Helmy Abd Wahab, Siti Zarina Mohd Muji, Fazliza Md. Nazir. “Integrated Billing System through GSM Network”. In Proceeding of 3rd International Conference on Robotics, Vision, Information and Signal Processing 2007 (ROVISP2007), Penang, 28 – 30 November 2007
- [6]. Mohd Helmy Abd Wahab, Azhar Ismail, Ayob Johari and Herdawatie Abdul Kadir. “SMS-Based Electrical Meter Reading”. In Proceeding of International Conference on Rural Information and Communication Technology 2009 (r-ICT), 17 – 18 June 2009, Bandung, Indonesia
- [7]. Malik Sikandar Hayat Khiyal, Aihab Khan, and Erum Shehzadi. “ SMS Based Wireless Home Appliance Control System (HACS) for Automating Appliances and Security”, Issues in Informing Science and Information Technology. Vol. 9. pp. 887 – 894. 2009.

## **AUTHOR DETAILS:**



**MADIREDDY RAHUL RAO** pursuing M.Tech (ES) from visvesvaraya college of engineering and technology, Patalguda, Ibrahimpatnam, Ranga Reddy dist, Telangana,INDIA.

	<p><b>M.SARITHA</b> working as Assisatant Professor, from Visvesvaraya college of Engineering and Technology, patelguda, Ibrahimpatnam, Rangareddy dist, Telangana, INDIA.</p>
	<p><b>H.RAGHUPATHI (HOD)</b>, working as Assistant Professor from Visvesvaraya College Of Engineering And Technology, Patelguda, Ibrahimpatnam, RangaReddy dist, Telangana, INDIA.</p>