

## DESIGN AND FABRICATION OF A SOLAR SPRAYER

S.Charvani<sup>1</sup>, K.Sowmya<sup>2</sup>, M.Malathi<sup>3</sup>, P.Rajani<sup>4</sup>, K.Saibaba<sup>5</sup>

<sup>1</sup>Department of H&S, Institute of Aeronautical Engineering, Hyderabad

### ABSTRACT

*In agriculture sector, spraying of pesticides is an important task to protect the crops from insects for obtaining high yield. However, farmers have been mainly using traditional conventional techniques like hand operated and fuel operated sprayer system for spraying pesticides. Fuel is expensive and in many places fuel may not be available. If hand operated spray systems are used, the labor productivity decreases and the efficiency will be low. The use of solar energy system is an alternate solution for these limitations.*

*Hence, a solar powered agricultural pesticide sprayer is designed and fabricated. The system was designed and fabricated by considering parameters like desired spraying capacity, low weight, low cost, user-friendly nature, high operating time and for faster coverage of area. Thus, the solar sprayer was fabricated to be a value for money product in the agricultural sector. For designing the prototype, the conventional sprayer system was studied to understand the mechanism for spraying process. Mathematical models were developed after adopting suitable assumptions for calculation of power of the motor required for spraying a known quantity of fluid. The parts required for the system were selected by solving for known input values and considering their availability in market. The system was fabricated and arrangements were made on the system to make it portable and to allow the user to carry it on his back while in operation. The system was fabricated according to the design parameters and field tested according to the standard test conditions.*

**Key points:** *Batter, DC pump, nozzle, solar sprayer, solar panel.*

### I. INTRODUCTION

A sprayer is a mechanical device used to spray the liquid like herbicides, pesticides, fungicides and fertilizers to the crops in order to avoid any pest and control the unwanted plant species. Sprayer provides optimum utilization of pesticides or any liquid with minimum efforts. In Indian farms generally two types of spray pumps are used for spraying, they are hand operated spray pump and fuel operated spray pump, out of which hand operated spray pumps are most popular. To kill the pests and insects pesticides, fertilizers are sprayed either manually or by using sprayers. Earlier, the pesticides and fertilizers were sprinkled manually, but they will result in harmful effects on farmers. In order to overcome this problem, different spraying techniques have been developed. These sprayers consist of different mechanisms and the cost of equipment is generally high. A solar operated sprayer is easy to handle and maintenance free, hence is affordable to the farmers. Therefore a solar operated sprayer is designed and fabricated.

This system can be operated using solar energy or electrical energy. The solar energy is converted into electrical energy and is stored in a storage battery. The main advantages of the present system are the running cost reduces to minimum and consume less time.

Solar energy from the sun is harvested on the solar panel. The panel is made up of photovoltaic cells, which converts photon energy to electric energy. These cells are made up of silicon semiconductor. Solar panel is used to generate electric energy and charge the battery. The charged battery is used to operate a DC pump for spraying the pesticides.

## II. FABRICATION OF SOLAR SPRAYER

Solar operated pesticide sprayer is fabricated to meet the demands of farmers such as reduced maintenance cost, shortage of electricity and fuel. The main parts of solar operated pesticide sprayer consist of Solar panel, DC Pump, Battery, Chemical tank, Nozzle, Spray gun etc.

### 2.1 Working principle

The system consists of Solar panel, charging unit, battery, pump and sprayer. The solar panel delivers an output in the order of 12 volts and 20 Watts power to the charging unit. The charging unit is used to strengthen the signal from the solar panel. The charging unit delivers the signal which charges the battery. According to the charged unit, the pump operates, such that the sprayer works. Here fertilizer can be stored in tank. When the sun rays are falling on the solar panel electricity will be generated through the solar cells and stored in the battery. By the electric power in the battery the pump operates and therefore fertilizers from the tank is sprayed out through the sprayers. The layout of solar sprayer is shown in fig.1. There is no maintenance cost and operating cost as it is using solar energy and no pollution problem. Its working principle is very easy and it is economical for the farmers, which has one more advantage that it can also generate power that power is saved in the battery and it can be used for both for spraying and well as to light in the houses when there is no current supply.

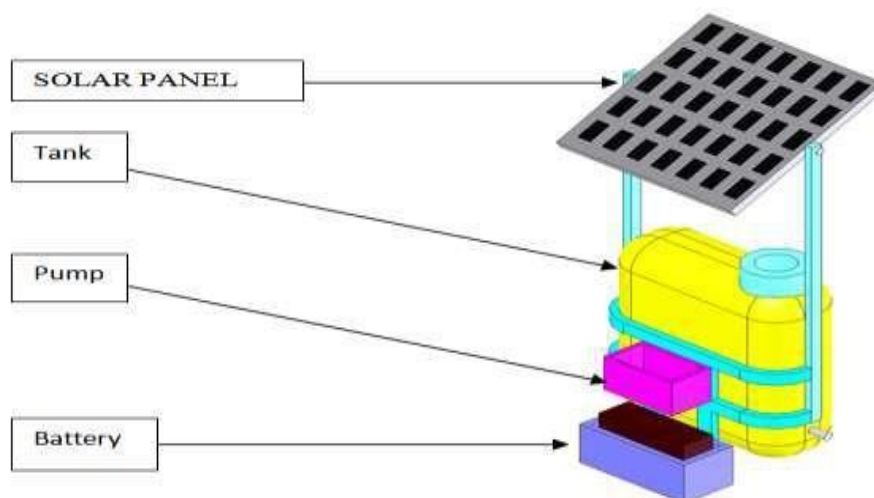

**Fig.1: Layout of Solar pesticide sprayer**

## 2.2 Block diagram

The block diagram of solar spray system is shown in Fig.2. It consists of five units namely: solar panel, charge controller, electrical circuit, pump, nozzle discharge. The details of each unit are described below.

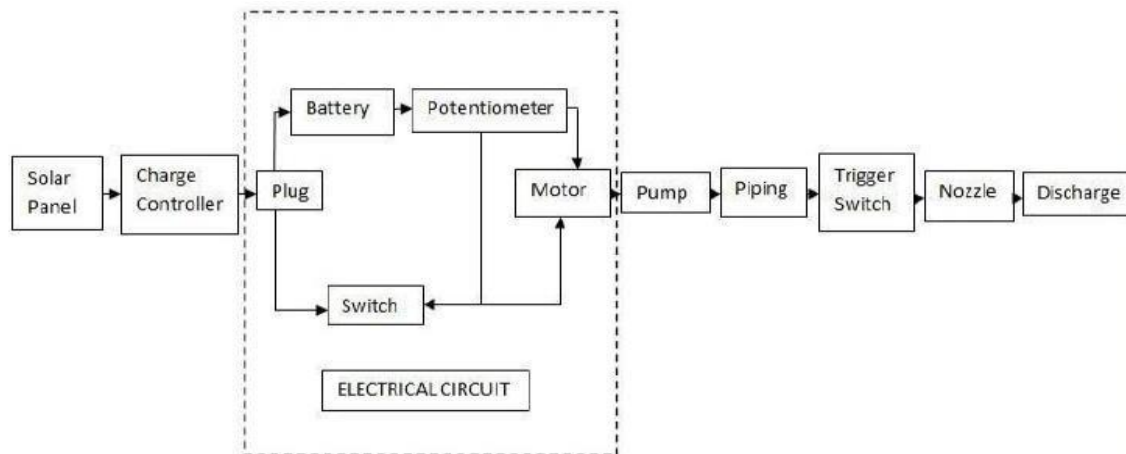

**Fig.2: Block diagram of spraying system**

In solar energy mode, solar energy obtained by the sun is converted into electrical energy using solar panel by photovoltaic effect. The output of energy conversion was used to charge a deep cycle battery. The number of times a battery can be discharged is known as its life cycle. For solar applications, a battery should be capable of being discharged in several times. In such cases a deep cycle battery is used. In this work a lead-acid accumulator serves the purpose. The lead-acid battery has the properties such as high current availability, contact voltage, longer life and more ability to charge as compare to conventional batteries.

The output of battery is connected to a DC pump through protection circuit. The DC pump is selected because of the advantages such as less in noise, longer in life, maintenance free, motor speed can be varied in the larger extent by varying the supply voltage and is self-lubricated. Pump is used to suck the spraying liquid from the sprayer tank and spray it through nozzle. The sprayer consists of sprayer tank and sprayer pipe. The sprayer tank is made up of plastic or fiber material in order to reduce the weight of the tank. The capacity of the tank is 16 liters and connected to the sprayer pipe with adjustable nozzle. By adjusting the nozzle the output of flow can be controlled. The whole unit can be carried conveniently at the back of human body with the help of shoulder straps. The supporting base of entire unit needs to be strong and light in weight.

## III. MATERIALS AND METHODOLOGY

It is observed that as the rating of solar panel increases, weight increases but the time for charging the battery decreases when solar panel is operating at its maximum rating. Thus, by considering weight and charging time

as the criteria, 20W rating solar panel was selected for fabricated solar system. The PV module is shown in Fig.3.

Table 1: Comparison of Solar Panels by Power Rating

S.No	Solar Panel Rating (W)	I=P/V (A) (V=12 volts)	T=Ah/I (hr)	Weight (kg)
1	6	6/12 = 0.5	8/0.5 = 16	0.6
2	8	8/12 = 0.667	8/0.667 = 12	0.8
3	10	10/12 = 0.83	8/0.83 = 9.63	1.2
4	15	15/12 = 1.25	8/1.25 = 6.4	1.5
5	20	20/12 = 1.67	8/1.67 = 4.79	2.0
6	30	30/12 = 2.5	8/2.5 = 3.2	3.6
7	40	40/12 = 3.33	8/3.33 = 2.402	5

**3.1 Specifications of Equipment**

The equipment details are mentioned in this section and the equipments are pesticide tank, DC motor, DC battery, nozzle type, solar panel.

**3.1.1 Liquid Storage Tank**

Tank capacity =16 ltrs.

Material = PVC

**3.1.2 DC Motor**

DC motor is used to lift the pesticide from tank and delivers to spray gun. DC motors has following specifications.

Model name: KF-2203

Voltage = 12 volts DC

Maximum current = 1.8 A

Maximum Pressure = 0.45 MPa

Liquid discharge = 2.9 lit/min

Speed = 0-6,000 rpm

**3.1.3 DC Battery**

Model name: Sealed lead acid battery 6DFM8.

Weight= 2.5 kg

Capacity = 12 volts, 8 Ah

Charging current = 2.4 A (Max)

Standby use: 13.5 V - 13.8 V

Cyclic use: 14.5 V - 14.9 V

**3.1.4 Nozzle**

Nozzle discharge rate is 2.9 lit/min.

**3.2 Solar panel**

**Table 2: Characteristics of Solar panel**

Model	ASL-S 2012
Electrical Characteristics	
Nominal power (Pmax)	20 W
Maximum voltage at Pmax, (Vmp)	18 V
Maximum current at Pmax, (Imp)	1.111 A
Open circuit voltage, (Voc)	21.6 DC
Short Circuit Current, (Isc)	1.244 A
Nominal Operating cell temperature	47°C ± 2°C
Temperature coefficient- power	0.00157%/°C
Standard Test Condition	Irradiance of 1000W/m <sup>2</sup> , Module temperature at 25° C
Primary Packing Box Dimension (LWH)	500 x 22 x 340 mm
Weight of Individual Module	2.0 kg
Cell Characteristics	
Type of Solar Cell	Poly Crystalline, 156x156mm±0.5mm
Number of Cells /Cell Size	36 / 22 x 156 mm
Arrangement of Cells	18 x 2
Frame	Anodized Aluminum alloy
Front Glass	3.2mm Tempered and Textured glass
Type of Junction Box	2 Terminal Polycarbonate

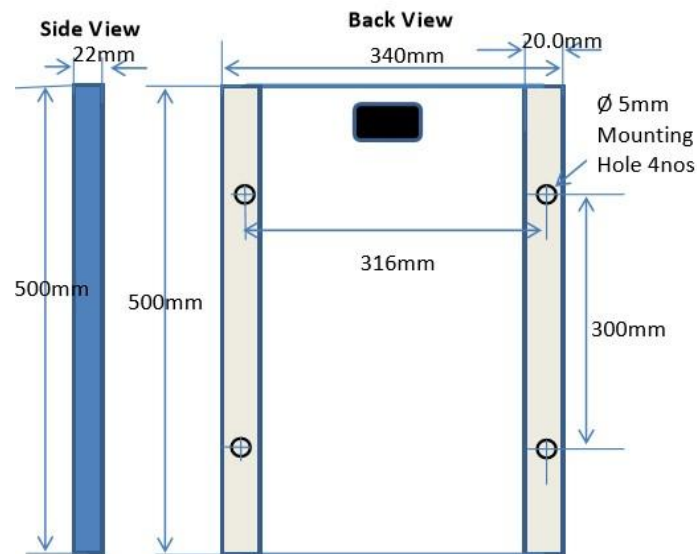

Fig.3: Photo voltaic module dimensions

#### IV. CALCULATIONS AND RESULTS

##### 4.1 Selection of Spray Pump

According to spraying capacity, the spray pump is selected.

Type: Centrifugal Pump.

Liquid Discharge = 2.9 lit/min.

Speed= 3600 rpm.

Power=3.5 W

##### 4.2 Selection of Battery

According to pump operating power, battery is selected.

Type : Lead acid battery.

Voltage=12 V

Current=8 A

When the circuit is short then, Voltage =12 V, Current = 2.4 A

Power = Voltage x Current = 12 x 2.4= 28.8 W

##### 4.3 Selection of solar panel

According to battery output power, solar panel is selected.

Power = 20 W

Dimensions: 500 mm x 22 mm x 340 mm

Weight =2.0 kg

Open Circuit Voltage =21.6 V

Short Circuit Current =1.318 A

Operating Current =1.176 A

#### 4.4 Current produced by panel and charging time of the battery

(i) The current produced by the solar panel (I) was calculated by knowing the maximum power (P) of the solar panel and the voltage rating (V) of the battery that is given by

$$I = P/V$$

Therefore,  $I = 20/12 = 1.66$  A

(ii). Charging time (T) was computed by taking the ratio rating of battery in ampere hour (Ah) to the total current supplied by the solar panel.

$$T = (\text{battery rating in ampere hour}) / (\text{total current consumed by the solar panel})$$

Therefore,  $T = 8 / 1.66 = 4.79$  hr

#### 4.5 Power Conversion Efficiency of the Panel

The solar cell power conversion efficiency can be calculated by using the relation,

$$\eta = \frac{P_{max}}{P_{in}} = \frac{\text{Output power}}{\text{Input power}}$$

Where,  $P_{in} = \text{Incident Solar radiation} \times \text{Area of the Solar Cell} = I_r \times A$

Performance parameters are under Standard test conditions at irradiance of 1000 W/m<sup>2</sup>

$$= 1000 (\text{W/m}^2) \times 22 \times 156 \times 10^{-6} (\text{m}^2) \times 36 = 123.552 \text{ W}$$

$$\text{The output power (P}_{out}) = V \times I = 17 \times 1.176 = 19.992 \text{ W}$$

$$\eta = \text{output power} / \text{input power}$$

$$\eta = 19.992/123.552 = 16.18 \%$$

This is the power conversion efficiency of the solar panel.

#### 4.6 Operating system of the solar panel

Charging can be done using a solar banal. Battery can be charged continuously by attaching the banal on the sprayers. Without panel on the sprayers, discharge can be done for a minimum period of 4 to 5 hours. By changing the battery, discharge can be continued for further more hours. During Rainy Season charging can be done by electrical devices.

The proposed system was tested with AC charging as well as solar charging. From the study it was found that the time required for charging the battery of 12V, 8Ah is 5 hours. The fully charged battery approximately spray 5-6 acres of land. It was also found that, if the battery is fully charged in a day it can be used to spray 200 liters of fertilizer. The initial cost of the proposed system is little more but the running cost of the system is very less. The developed system used for spraying the fertilizer, pesticides, fungicides.

The fabricated solar operated sprayer is shown in Fig.4. The solar panel is attached to spray pump in such a way that, it come exactly on the tank. Based on experiments, it is found that charged solar pump sprays can used during day time between 9 AM to 5 PM. All the tests are successfully carried out at the same time. Fully

charged solar spray pump works for 7-8 hrs continuously and at the same time it will be charged. Hence this modern model is more effective and eco-friendly than hand operated and fuel operated spray pump.



**Fig.4: Fabricated solar pesticide sprayer**

## V. CONCLUSIONS

The main findings of the designed and fabricated solar sprayer are:

1. The prepared solar operated sprayer is environment friendly and cost efficient.
2. The prepared solar operated sprayer can be used largely in agriculture field effectively.
3. The prepared solar pesticide sprayer is the best option to farmer who economically challenged and facing electrical problems like load shedding etc.
4. It does not create air pollution and noise.
5. It does not require fuel hence it is a zero fuel operated equipment.
6. It can use in municipality for killing insects and mosquitoes.
7. It is maintenance free device.
8. It is easy to operate and portable.

The solar operated sprayer will help the farmers of those remote areas of country where fuel is not available easily. They can perform their regular work as well as saves fuel up to large extent. At the same time they can do their pesticide spraying work with very less environment pollution.

## REFERENCES

- [1] R. Rajesh, V. Vimal kingsley, M. Selva pandi, G. Niranjana, G. Varun harshath, Design and Fabrication of Solar Pesticide Sprayer, International Journal of Innovative Research in Science, Engineering and Technology, Vol. 5, Special Issue 8, 2016.
- [2] Sarvesh Kulkarni, Karan Hasurkar, Ramdas Kumbhar, Amol Gonde, Raut A.S., Review of Solar Powered Pesticide Sprayer, International Journal of Research in Advent Technology, Vol.3, No.4, April 2015 E-ISSN: 2321-9637



- [3] Pandurang Lad, Virendra Patil , Prashant Patil, Tushar Pati, Pravin Patil, Solar operated pesticide sprayer, International Journal of Advance Research In Science And Engineering IJARSE, Vol. No.4, Special Issue (01), April 2015 ISSN-2319-8354(E)
- [4] R. Joshua, V. Vasu and P. Vincent, Solar Sprayer - An Agriculture Implement, International Journal of Sustainable Agriculture 2 (1): 16-19, 2010 ISSN 2079-2107© IDOSI Publications, 2010
- [5] M.Y. Hussain, Islam-ud-din, and M.Anwar, “Dehydration of Agriculture Products by Mixed Mode Solar Dehydrator” International journal of Agriculture and Biology, ISSN Online: 1814-9596.
- [6] Sonali Goel, Prajnasmitha Mohapatra and R.K.Pati, “Solar Application for Transfer of Technology” Special issue of International journal of Power System Operation and Energy management, volume 1, Issue 3, Pages67-71.